



GT-100

COSM AMP EFFECTS PROCESSOR



Parameter Guide

BOSS

Contents

Basic Operation	3	DIVIDER.....	22
EZ TONE	4	SINGLE.....	22
PATCH CREATE.....	4	DUAL Ch. A, DUAL Ch. B.....	22
AMP CUSTOMIZE.....	4	MIXER.....	22
OD/DS CUSTOMIZE.....	4	SEND/RETURN.....	23
EFFECT	5	NS1/NS2.....	23
COMP.....	5	ACCEL FX.....	24
OD/DS.....	5	S-BEND.....	24
PREAMP.....	6	LASER BEAM.....	24
EQ.....	8	RING MOD.....	24
FX1/FX2.....	9	TWIST.....	24
T. WAH.....	10	WARP.....	24
AUTO WAH.....	10	FEEDBACKER.....	24
SUB WAH.....	10	MASTER SETTING.....	25
ADV. COMP.....	10	MASTER SETTING.....	25
LIMITER.....	11	MASTER EQ.....	25
SUB OD/DS.....	11	AMP CONTROL.....	25
GRAPHIC EQ.....	11	SYSTEM	26
PARAMETRIC EQ.....	11	OUTPUT SELECT.....	26
TONE MODIFY.....	11	INPUT.....	26
GUITAR SIM.....	12	GLOBAL EQ.....	26
SLOW GEAR.....	12	TOTAL.....	26
DEFRETTER.....	12	PHRASE LOOP.....	26
WAVE SYNTH.....	12	PLAY OPTION.....	26
SITAR SIM.....	13	KNOB SETTING.....	27
OCTAVE.....	13	PREFERENCE.....	28
PITCH SHIFTER.....	13	LCD.....	28
HARMONIST.....	14	USB.....	28
SOUND HOLD.....	14	MIDI SETTING.....	29
AC. PROCESSOR.....	15	MIDI PROGRAM MAP BANK 0-3.....	30
PHASER.....	15	MIDI BULK DUMP.....	30
FLANGER.....	15	PEDAL CALIBRATION.....	30
TREMOLO.....	16	AUTO OFF.....	30
ROTARY.....	16	FACTORY RESET.....	30
UNI-V.....	16	CTL/EXP	31
PAN.....	16	ACCEL/CTL, EXP SW, SUB CTL 1, SUB CTL 2.....	31
SLICER.....	17	EXP, SUB EXP.....	31
VIBRATO.....	17	ASSIGN COMMON.....	32
RING MOD.....	17	ASSIGN 1-8.....	32
HUMANIZER.....	17	Virtual expression pedal system (Internal Pedal / Wave Pedal).....	35
2X2 CHORUS.....	18	Input Level.....	35
SUB DELAY.....	18	Other Settings	37
DELAY.....	19	TUNER METRONOME MODE.....	37
CHORUS.....	20	TUNER.....	37
REVERB.....	20	METRONOME.....	37
PEDAL FX.....	21	MANUAL MODE.....	37
PEDAL BEND.....	21		
WAH.....	21		
FOOT VOLUME.....	21		
FOOT VOLUME.....	21		

Memo

-  This effect sound is mono.
-  This effect sound is output with two channels.
-  These effects take a mono input and output it on two channels.

* The product names mentioned in this document are registered trademarks or trademarks of their respective owners. In this manual, these names are used because it is the most practical way of describing the sounds that are simulated using COSM technology.

Copyright © 2012 BOSS CORPORATION

All rights reserved. No part of this publication may be reproduced in any form without the written permission of BOSS CORPORATION.

Basic Operation

Editing on the GT-100 is extremely simple; the procedure is always the same..

1 Choose what you're going to edit

Press one of the following buttons.

Effect

Here you can edit the parameters of each effect.

page 5

EZ (Easy) Tone

Here you can create the desired tone simply by choosing a musical style and the type of song you have in mind. You can also customize the amp and overdrive/distortion settings in an intuitive way.

page 4

EFFECT SYSTEM

EZ TONE CTL/EXP



System

Here you can make settings that apply to the entire GT-100, such as output settings and phrase loop settings.

page 26

Control/Expression

Here you can assign the desired functions to the [ACCEL/CTL] pedal, [EXP] pedal, and external pedals.

page 31

2 Select an item



Use knob [4] to select an item shown in the left display.

The screen shown here is an example of when you've pressed the [EFFECT] button.

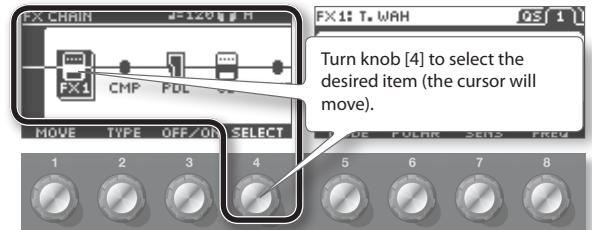

Turn knob [4] to select the desired item (the cursor will move).

3 Edit the values

Use knobs [5-8] to edit the values shown in the right display.

If page tabs are shown in the screen, you can use the [PAGE] buttons to move between tabs.

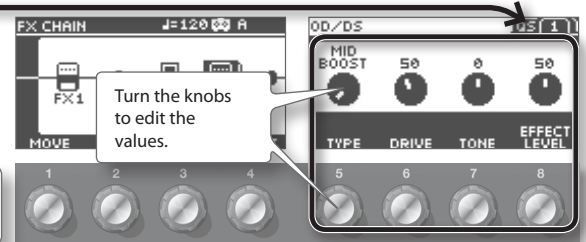

Turn the knobs to edit the values.

4 Exit the settings



Press [EXIT].

You'll be returned to the Play screen.

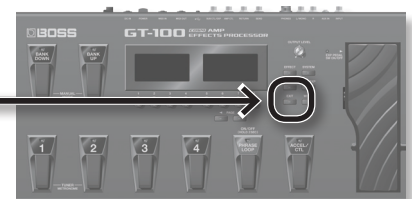

NOTE

The settings you've edited will be lost when you switch patches. If you want to keep the edited settings, you must save them as a user patch (Owner's Manual: p. 13).

PATCH CREATE

Lets you easily create your sound starting from your choice of musical style and type of song.

Parameter	Value	Explanation
BASIC TONE	BLUES	Blues sound
	Soul Funk	Soul and Funk sound
	Jazz	Jazz sound
	LIVERPOOL	British Rock
	70's HARD ROCK	The Hard Rock sound popular in the '70s
	80s METAL	The Metal sound popular in the '80s
	MODERN METAL	Modern Metal sound
	West Coast	West Coast sound
	Fuzz Rock	Fuzz
	STUDIO	Recording Studio
	PROGRESSIVE	Progressive
	SURF ROCK	Surf Rock sound
	COUNTRY	Country
	Acoustic	For Acoustic Guitar
	Punk Pop	Punk Pop
SOFT -HARD	-50+50	+: Sharp distortion -: Warm distortion
BACKING - SOLO	-50+50	+: For soloing -: For backing
AMBIENCE	0-100	Adjusts the length of the resonance

AMP CUSTOMIZE

Lets you intuitively customize the amp.

Parameter	Value	Explanation
CUSTOM TYPE	JC CLEAN	This models the sound of the Roland JC-120.
	TW CLEAN	This models a Fender Twin Reverb.
	CRUNCH	This is a crunch sound that can faithfully reproduce the nuances of picking.
	COMBO DRIVE	This is a combo amp sound that it suited to sixties-style British rock.
	COMBO LEAD	This is a lead sound of a combo tube amp typical of the late '70s to '80s.
	MS HiGAIN	This models the sound input to Input I on a Marshall 1959. This is a trebly sound suited to hard rock.
	MODERN STACK	This original high-gain amp delivers thick lows and intense distortion while still preserving the sound's clear definition.
SOFT -HARD	-50+50	+: Sharp distortion -: Warm distortion
BACKING - SOLO	-50+50	+: For soloing -: For backing

OD/DS CUSTOMIZE









Lets you intuitively customize the overdrive/distortion.

Parameter	Value	Explanation
CUSTOM TYPE	OD-1	This models the sound of the BOSS OD-1.
	OD-2	This is a overdrive sound with high gain.
	CRUNCH	This is a crunch sound.
	DS-1	This gives a basic, traditional distortion sound.
	DS-2	This creates a heavier distortion sound.
	METAL1	This is a metal sound with a characteristic midrange.
	METAL2	This gives a heavy metal sound.
	FUZZ	This gives a basic, traditional fuzz sound.
	SOFT -HARD	-50+50
BACKING - SOLO	-50+50	+: For soloing -: For backing

COMP

STEREO MONO

This is an effect that produces a long sustain by evening out the volume level of the input signal.

Parameter	Value	Explanation
ON/OFF	OFF, ON	Turns this effect on/off.
TYPE	BOSS COMP 	This models a BOSS CS-3.
	HI-BAND 	This is a compressor that adds an even stronger effect in the high end.
	LIGHT 	This is a compressor with a light effect.
	D-COMP 	This models a MXR DynaComp.
	ORANGE 	This is modeled on the sound of the Dan Armstrong ORANGE SQUEEZER.
	FAT 	When applied heavily, this compressor effect provides a fat tone with a boosted midrange.
	MILD 	When applied heavily, this compressor effect produces a sweet tone with the high end cut.
	STEREO COMP 	This selects a stereo compressor.
SUSTAIN	0–100	Adjusts the range (time) over which low-level signals are boosted. Larger values will result in longer sustain.
ATTACK	0–100	Adjusts the attack time.
LEVEL	0–100	Adjusts the tone.
TONE	-50–+50	Adjusts the volume.

OD/DS

MONO

This effect distorts the sound to create long sustain.

Parameter	Value	Explanation
ON/OFF	OFF, ON	Turns this effect on/off.
TYPE	Refer to OD/DS TYPE	
DRIVE	0–120	Adjusts the depth of distortion.
TONE	-50–+50	Adjusts the tone.
EFFECT LEVEL	0–100	Adjusts the volume of the OD/DS sound.
BOTTOM	-50–+50	Adjusts the tone for the low frequency range. Turning this to the left (counterclockwise) produces a sound with the low end cut; turning it to the right boosts the low end in the sound.
DIRECT MIX	0–100	Adjusts the volume of the direct sound.
SOLO SW	OFF, ON	The tone to one suitable for solos.
SOLO LEVEL	0–100	Adjusts the volume level when the Solo Sw is ON.

OD/DS TYPE

This is a list of distortion types that can be selected for OD/DS.

Category	Type	Explanation
ADVANCED	MID BOOST	This is a booster with unique characteristics in the midrange. Making the connection before the COSM amp produces sound suitable for solos.
	CLEAN BOOST	This not only functions as a booster, but also produces a clean tone that has punch even when used alone.
	TREBLE BOOST	This is a booster that has bright characteristics.
	CRUNCH	A lustrous crunch sound with an added element of amp distortion.
	NATURL OD	This is an overdrive sound that provides distortion with a natural feeling.
	WARM OD	This is a warm overdrive.
	FAT DS	A distortion sound with thick distortion.
	LEAD DS	Produces a distortion sound with both the smoothness of an overdrive along with a deep distortion.
	METAL DS	This is distortion sound that is ideal for performances of heavy riffs.
	OCT FUZZ	A fuzz sound with rich harmonic content.
VINTAGE	BLUES OD	This is a crunch sound of the BOSS BD-2. This produces distortion that faithfully reproduces the nuances of picking.
	OD-1	This models the sound of the BOSS OD-1. This produces sweet, mild distortion.
	T-SCREAM	This models an Ibanez TS-808.
	TURBO OD	This is the high-gain overdrive sound of the BOSS OD-2.
	DIST	This gives a basic, traditional distortion sound.
	RAT	This models a Proco RAT.
	GUV DS	This models a Marshall GUV' NOR.
	DST+	This models a MXR DISTORTION+.
	METAL ZONE	This models the sound of the BOSS MT-2. It produces a wide range of metal sounds, from old style to slash metal.
	'60S FUZZ	This models a FUZZFACE. It produces a fat fuzz sound.
MUFF FUZZ	This models an Electro-Harmonix Big Muff π.	
CUSTOM		Custom OD/DS
		You can customize it however you like to match the sound you want.

CUSTOM OD/DS SETTING

Parameter	Value	Explanation
CUSTOM TYPE	OD-1	This models the sound of the BOSS OD-1.
	OD-2	This is an overdrive sound with high gain.
	CRUNCH	This is a crunch sound.
	DS-1	This gives a basic, traditional distortion sound.
	DS-2	This creates a heavier distortion sound.
	METAL1	This is a metal sound with a characteristic midrange.
	METAL2	This gives a heavy metal sound.
	FUZZ	This gives a basic, traditional fuzz sound.
CUSTOM CHAR	-50+50	+ : For soloing - : For backing
CUSTOM BOTTOM	-50+50	This controls the input sound's low-frequency range and adjusts the amount of distortion in the low-frequency range
CUSTOM TOP	-50+50	This controls the input sound's high-frequency range and adjusts the amount of distortion in the high-frequency range.
CUSTOM LOW	-50+50	Adjusts the low-range tones after distortion is applied.
CUSTOM HIGH	-50+50	Adjusts the high-range tones after distortion is applied.

PREAMP

MONO

COSM technology simulates different preamp characteristics, speaker sizes, and cabinet shapes.

Parameter	Value	Explanation
ON/OFF	OFF, ON	Turns the COSM AMP effect on/off.
TYPE	Refer to PREAMP TYPE	
GAIN	0-120	Adjusts the distortion of the amp.
T-COMP	-10-0+10	Adjusts the sense of compression of the amp.
LEVEL	0-100	Adjusts the volume of the entire preamp. * Be careful not to raise the Level setting too high.
BASS	0-100	Adjusts the tone for the low frequency range.
MIDDLE	0-100	Adjusts the tone for the middle frequency range.
TREBLE	0-100	Adjusts the tone for the high frequency range.
PRESENCE	0-100	Adjusts the tone for the ultra high frequency range. * The PRESENCE parameter functions as a high-cut filter with some PREAMP TYPES.
BRIGHT	OFF, ON	Turns the bright setting on/off. * The BRIGHT parameter setting is available only with certain PREAMP TYPES.
GAIN SW	LOW, MIDDLE, HIGH	Provides for selection from three levels of distortion: LOW, MIDDLE, and HIGH. Distortion will successively increase for settings of LOW, MIDDLE and HIGH. * The sound of each Type is created on the basis that the Gain is set to MIDDLE. So, normally set it to MIDDLE.
SOLO SW	OFF, ON	SOLO SW is switched on to create the tone to one suitable for solos.
SOLO LEVEL	0-100	Adjusts the volume level when the SOLO SW is ON.

Parameter	Value	Explanation
SP TYPE *1		Select the speaker type.
	OFF	This turns off the speaker simulator.
	ORIGIN (ORIGINAL)	This is the built-in speaker of the amp you selected with PREAMP TYPE.
	1x8"	This is a compact open-back speaker cabinet with one 8-inch speaker.
	1x10"	This is a compact open-back speaker cabinet with one 10-inch speaker.
	1x12"	This is a compact open-back speaker cabinet with one 12-inch speaker.
	2x12"	This is a general open-back speaker cabinet with two 12-inch speakers.
	4x10"	This is an optimal speaker cabinet for a large enclosed amp with four 10-inch speakers.
	4x12"	This is an optimal speaker cabinet for a large enclosed amp with four 12-inch speakers.
	8x12"	This is a double stack of two cabinets, each with four 12-inch speakers.
	CUSTOM	Custom speaker You can customize it however you like to match the sound you want.
MIC TYPE *1		This setting selects the simulated mic type.
	DYN57	This is the sound of the SHURE SM-57. General dynamic mic used for instruments and vocals. Optimal for use in miking guitar amps.
	DYN421	This is the sound of the SENNHEISER MD-421. Dynamic mic with extended low end.
	CND451	This is the sound of the AKG C451B. Small condenser mic for use with instruments.
	CND87	This is the sound of the NEUMANN U87. Condenser mic with flat response.
	FLAT	Simulates a mic with perfectly flat response. Produces a sonic image close to that of listening to the sound directly from the speakers (on site).
MIC DIS *1		Simulates the distance between the mic and speaker.
	OFF MIC	This setting points the mic away from the speaker.
	ON MIC	Provides conditions whereby the mic is directed more towards the speaker.
MIC POS *1		This simulates the mic position.
	CENTER	Simulates the condition that the mic is set in the middle of the speaker cone.
	1-10 cm	Simulates the condition that the mic is moved away from the center of the speaker cone.
MIC LEVEL *1	0-100	Adjusts the volume of the mic.
DIRECT MIX *1	0-100	Adjusts the volume of the direct sound.

*1 This is enabled when the OUTPUT SELECT parameter is set to LINE/PHONE.

PREAMP TYPE

This is a list of the amp types that can be selected for PREAMP.

Category	Type	Explanation
ADVANCED	NATURL CLEAN	An unembellished, clean sound that minimizes the amp's idiosyncrasies, such as its trebly character and boomy low end.
	FULL RANGE	An amp with a broad frequency range and an extremely flat response. Good for acoustic guitar.
	COMBO CRUNCH	Crunch sound that allows the nuances of your picking to be expressed even more faithfully than on conventional combo amps.
	STACK CRUNCH	Great-feeling crunch sound that responds well to picking dynamics while retaining all the defining characteristics of a 4 x 12" speaker cabinet.
	HIGAIN STACK	High-gain sound of a vintage Marshall specially revamped in a way that is possible only with COSM modeling technology.
	POWER DRIVE	A straight drive sound that works well in a broad range of situations, from backing to lead. A sound like this cannot be obtained from any existing combo amp or stack amp.
	EXTREM LEAD	A new type of sound that smoothes out the uneven frequency response that is typical of existing large stack amps.
	CORE METAL	A large stack sound that has been tweaked extensively in the pursuit of the ultimate metal sound.
VINTAGE	JC-120	This models the sound of the Roland JC-120.
	CLEAN TWIN	This models a Fender Twin Reverb.
	PRO CRUNCH	This models a Fender Pro Reverb.
	TWEED	This models a Fender Bassman 4 x 10" Combo.
	DELUXE CRUNCH	This models a Fender Deluxe Reverb.
	VO DRIVE	This models the drive sound of a VOX AC-30TB. This is a sound that it suited to sixties-style British rock.
	VO LEAD	This models the lead sound of the VOX AC-30TB.
	MATCH DRIVE	This models the sound input to left input on a Matchless D/C-30. A simulation of the latest tube amp widely used in styles from blues and rock.
	BG LEAD	This models the lead sound of the MESA/Boogie combo amp. The sound of a tube amp typical of the late '70s to '80s.
	BG DRIVE	This models a MESA/Boogie with TREBLE SHIFT SW on.
	MS1959 I	This models the sound input to Input I on a Marshall 1959. This is a trebly sound suited to hard rock.
	MS1959 I+II	The sound of connecting inputs I and II of the guitar amp in parallel, creating a sound with a stronger low end than I.
	R-FIER VINTAGE	Models the sound of the Channel 2 VINTAGE Mode on the MESA/Boogie DUAL Rectifier.
	R-FIER MODERN	Models the sound of the Channel 2 MODERN Mode on the MESA/Boogie DUAL Rectifier.
	T-AMP LEAD	This models a Hughes & Kettner Triamp AMP3.
SLDN	This models a Soldano SLO-100. This is the typical sound of the eighties.	
5150 DRIVE	This models the lead channel of a Peavey EVH 5150.	

Category	Type	Explanation
CUSTOM		This is a custom preamp. You can customize it however you like to match the sound you want.

CUSTOM AMP SETTING

Parameter	Value	Explanation
CUSTOM TYPE	JC CLEAN	This models the sound of the Roland JC-120.
	TW CLEAN	This models a Fender Twin Reverb.
	CRUNCH	This is a crunch sound that can faithfully reproduce the nuances of picking.
	COMBO DRIVE	This is a combo amp sound that it suited to sixties-style British rock.
	COMBO LEAD	This is a lead sound of a combo tube amp typical of the late '70s to '80s.
	MS HIGAIN	This models the sound input to Input I on a Marshall 1959. This is a trebly sound suited to hard rock.
	MODERN STACK	This original high-gain amp delivers thick lows and intense distortion while still preserving the sound's clear definition.
CUSTOM CHAR	-50+50	+: For soloing -: For backing
CUSTOM BOTTOM	-50+50	This controls the input sound's low-frequency range and adjusts the amount of distortion in the low-frequency range.
CUSTOM EDGE	-50+50	This controls the input sound's high-frequency range and adjusts the amount of distortion in the high-frequency range.
CUSTOM PREAMP LOW	-50+50	Adjusts the preamp section's low-frequency tone.
CUSTOM PREAMP HIGH	-50+50	Adjusts the preamp section's high-frequency tone.

CUSTOM SPEAKER SETTING

Parameter	Value	Explanation
CUSTOM SP SIZE	5-15"	Selects the size of speaker.
CUSTOM SP NUMBER	x1, x2, x4, x8	Sets the number of speakers.
CUSTOM CABINET	Selects the speaker cabinet type.	
	OPEN	This is an open-backed cabinet
	CLOSE	This type of cabinet features an enclosed rear panel.
CUSTOM COLOR LOW	-10+10	Adjusts the speaker section's low-frequency tone.
CUSTOM COLOR HIGH	-10+10	Adjusts the speaker section's high-frequency tone.

EQ

STEREO

This adjusts the tone as an equalizer. A parametric type is adopted for the high-middle and low-middle range.

Parameter	Value	Explanation
ON/OFF	OFF, ON	Turns this effect on/off.
LOW GAIN	-20+20 dB	Adjusts the low frequency range tone.
HIGH GAIN	-20+20 dB	Adjusts the high frequency range tone.
LEVEL	-20+20 dB	Adjusts the overall volume level of the equalizer.
LOW-MID FREQ	20 Hz-10.0 kHz	Specifies the center of the frequency range that will be adjusted by the LOW-MID GAIN.
LOW-MID Q	0.5-16	Adjusts the width of the area affected by the EQ centered at the LOW-MID FREQ. Higher values will narrow the area.
LOW-MID GAIN	-20+20 dB	Adjusts the low-middle frequency range tone.
HIGH-MID FREQ	20 Hz-10.0 kHz	Specifies the center of the frequency range that will be adjusted by the HIGH-MID GAIN.
HIGH-MID Q	0.5-16	Adjusts the width of the area affected by the EQ centered at the HIGH-MID FREQ. Higher values will narrow the area.
HIGH-MID GAIN	-20+20 dB	Adjusts the low-middle frequency range tone.
LOW CUT	FLAT, 20 Hz-800 Hz	This sets the frequency at which the low cut filter begins to take effect. When FLAT is selected, the low cut filter will have no effect.
HIGH CUT	630 Hz- 12.5 kHz, FLAT	This sets the frequency at which the high cut filter begins to take effect. When FLAT is selected, the high cut filter will have no effect.

FX1/FX2

With FX1 and FX2, you can select the effect to be used from the following. You can select the same effect for FX1 and FX2.

Parameter	Value	Explanation
ON/OFF	OFF, ON	Turns this effect on/off.
TYPE	Refer to FX1/FX2 TYPE	

FX1/FX2 TYPE

This is a list of the effects that can be selected for FX1/FX2.

Effect Name	Explanation
T. WAH (Touch Wah)	You can produce a wah effect with the filter changing in response to the guitar level.
AUTO WAH (Auto Wah)	This changes the filtering over a periodic cycle, providing an automatic wah effect.
SUB WAH	You can control the wah effect in real time by adjusting the [EXP] pedal or the expression pedal connected to the SUB CTL 1, 2/SUB EXP jack.
ADV. COMP (Advanced Compressor)	This is an effect that produces a long sustain by evening out the volume level of the input signal. You can also use it as a limiter to suppress only the sound peaks and prevent distortion.
LIMITER	The limiter attenuates loud input levels to prevent distortion.
SUB OD/DS	This effect distorts the sound to create long sustain.
GRAPHIC EQ (Graphic Equalizer)	This adjusts the tone as an equalizer. You can adjust the sound quality in ten bands.
PARAMETRIC EQ (Parametric Equalizer)	Adjusts the tonal quality. You can adjust the sound quality in four bands.
TONE MODIFY	This changes the tone of the connected guitar.
GUITAR SIM (Guitar Simulator)	Simulation of the characteristics of particular guitar components such as pickups and different guitar bodies allows you to switch among a number of different guitar types all while using a single guitar.
SLOW GEAR	This produces a volume-swell effect ("violin-like" sound).
DEFRETTER	This simulates a fretless guitar.
WAVE SYNTH	This is a synth sound that processes the guitar input signal.
SITAR SIM. (Sitar Simulator)	This simulates the sound of the sitar.
OCTAVE	This adds a note one octave lower, creating a richer sound.
PITCH SHIFTER	This effect changes the pitch of the original sound (up or down) within a range of two octaves.
HARMONIST	Harmonist is an effect where the amount of shifting is adjusted according to an analysis of the guitar input, allowing you to create harmony based on diatonic scales.
SOUND HOLD	You can have sound played on the guitar be held continuously. This effect allows you to perform the melody in the upper registers while holding a note in the lower registers.
AC. PROCES- SOR (Acoustic Processor)	This processor allows you to change the sound produced by the pickup on an acoustic electric guitar, creating a richer sound similar to that obtained with a microphone placed close to the guitar.
PHASER	By adding varied-phase portions to the direct sound, the phaser effect gives a whooshing, swirling character to the sound.
FLANGER	The flanging effect gives a twisting, jet-airplane-like character to the sound.
TREMOLO	Tremolo is an effect that creates a cyclic change in volume.
ROTARY	This produces an effect like the sound of a rotary speaker.
UNI-V	This models a Uni-Vibe. Although this resembles a phaser effect, it also provides a unique undulation that you can't get with a regular phaser.

Effect Name	Explanation
PAN	With the volume level of the left and right sides alternately changing, when playing sound in stereo, you can get an effect that makes the guitar sound appear to fly back and forth between the speakers.
SLICER	This consecutively interrupts the sound to create the impression that a rhythm backing phrase is being played.
VIBRATO	This effect creates vibrato by slightly modulating the pitch.
RING MOD.	This creates a bell-like sound by ring-modulating the guitar sound with the signal from the internal oscillator. The sound can be unmusical and lack distinctive pitches.
HUMANIZER	This can create human vowel-like sounds.
2X2 CHORUS	Frequency band division is employed to produce two different choruses, one for low frequencies and one for higher frequencies, for both the left and right channels (for a total of four). This allows you to achieve a more natural chorus sound.
SUB DELAY	This is a delay with the maximum delay time of 1,000 ms. This effect is useful for making the sound fatter.

EFFECT

T. WAH

MONO

You can produce a wah effect with the filter changing in response to the guitar level.

Parameter	Value	Explanation
MODE	Selects the wah mode.	
	LPF	This creates a wah effect over a wide frequency range.
	BPF	This creates a wah effect in a narrow frequency range.
POLAR	Selects the direction in which the filter will change in response to the input.	
	DOWN	The frequency of the filter will fall.
	UP	The frequency of the filter will rise.
SENS	0–100	Adjusts the sensitivity at which the filter will change in the direction determined by the polarity setting. Higher values will result in a stronger response. With a setting of 0, the strength of picking will have no effect.
FREQ	0–100	Adjusts the center frequency of the Wah effect.
PEAK	0–100	Adjusts the way in which the wah effect applies to the area around the center frequency. Higher values will produce a stronger tone which emphasizes the wah effect more. With a value of 50 a standard wah sound will be produced.
EFFECT LEVEL	0–100	Adjusts the volume of the effect sound.
DIRECT MIX	0–100	Adjusts the volume of the direct sound.

AUTO WAH

MONO

This changes the filtering over a periodic cycle, providing an automatic wah effect.

Parameter	Value	Explanation
MODE	Selects the wah mode.	
	LPF	This creates a wah effect over a wide frequency range.
	BPF	This creates a wah effect in a narrow frequency range.
RATE	0–100, BPM 	Adjusts the frequency (speed) of the change. * When set to BPM, the value of each parameter will be set according to the value of the "MASTER BPM" specified for each patch. This makes it easier to achieve effect sound settings that match the tempo of the song. * If, due to the tempo, the time is longer than the range of allowable settings, it is then synchronized to a period either 1/2 or 1/4 of that time.
DEPTH	0–100	Adjusts the depth of the effect.
FREQ	0–100	Adjusts the center frequency of the Wah effect.
PEAK	0–100	Adjusts the amount of wah effect applied in the range near the center frequency. Higher values will produce a stronger tone which emphasizes the wah effect more. With a value of 50 a standard wah sound will be produced.
EFFECT LEVEL	0–100	Adjusts the volume of the effect sound.
DIRECT MIX	0–100	Adjusts the volume of the direct sound.

SUB WAH

MONO

You can control the wah effect in real time by adjusting the [EXP] pedal or the expression pedal connected to the SUB CTL 1, 2/SUB EXP jack.









Parameter	Value	Explanation
TYPE	Selects the type of wah.	
	CRY WAH	This models the sound of the CRY BABY wah pedal popular in the '70s.
	VO WAH	This models the sound of the VOX V846.
	FAT WAH	This is a wah sound featuring a bold tone.
	LIGHT WAH	This wah has a refined sound with no unusual characteristics.
	7STRING WAH	This expanded wah features a variable range compatible with seven-string and baritone guitars.
RESO WAH	This completely original effect offers enhancements on the characteristic resonances produced by analog synth filters.	
	Adjusts the position of the wah pedal.	
PEDAL POS	0–100	* This parameter is used after it's been assigned to an EXP Pedal or similar controller.
PEDAL MIN	0–100	Selects the tone produced when the heel of the EXP Pedal is depressed.
PEDAL MAX	0–100	Selects the tone produced when the toe of the EXP Pedal is depressed.
EFFECT LEVEL	0–100	Adjusts the volume of the effect sound.
DIRECT MIX	0–100	Adjusts the volume of the direct sound.

ADV. COMP

STEREO

MONO

This is an effect that produces a long sustain by evening out the volume level of the input signal. You can also use it as a limiter to suppress only the sound peaks and prevent distortion.

Parameter	Value	Explanation
TYPE	Selects the compressor type.	
	BOSS COMP 	This models a BOSS CS-3.
	HI-BAND 	This is a compressor that adds an even stronger effect in the high end.
	LIGHT 	This is a compressor with a light effect.
	D-COMP 	This models a MXR DynaComp.
	ORANGE 	This is modeled on the sound of the Dan Armstrong ORANGE SQUEEZER.
	FAT 	When applied heavily, this compressor effect provides a fat tone with a boosted midrange.
	MILD 	When applied heavily, this compressor effect produces a sweet tone with the high end cut.
	STEREO COMP 	This selects a stereo compressor.
SUSTAIN	0–100	Adjusts the range (time) over which low-level signals are boosted. Larger values will result in longer sustain.
ATTACK	0–100	Adjusts the attack time.
LEVEL	0–100	Adjusts the volume.
TONE	-50+50	Adjusts the tone.

LIMITER

STEREO

The limiter attenuates loud input levels to prevent distortion.

Parameter	Value	Explanation
TYPE	Selects the limiter type.	
	BOSS LIMITER	This selects a stereo limiter.
	RACK 160D	This models a dbx 160X.
	VTG RACK U	This models a UREI 1178.
THRESH	0–100	Adjust this as appropriate for the input signal from your guitar. When the input signal level exceeds this threshold level, limiting will be applied.
RATIO	1:1–INF:1	This selects the compression ratio used with signals in excess of the threshold level.
LEVEL	0–100	Adjusts the volume.
ATTACK	0–100	Adjusts the strength of the picking attack when the strings are played. Higher values result in a sharper attack, creating a more clearly defined sound.
RELEASE	0–100	Adjusts the release time.

SUB OD/DS

MONO

This effect distorts the sound to create long sustain.

Parameter	Value	Explanation
TYPE	Refer to "OD/DS TYPE" (p. 5) * "CUSTOM" is not available.	
DRIVE	0–120	Adjusts the depth of distortion.
TONE	-50–+50	Adjusts the tone.
EFFECT LEVEL	0–100	Adjusts the volume of the OD/DS sound.
BOTTOM	-50–+50	Adjusts the tone for the low frequency range. Turning this to the left (counterclockwise) produces a sound with the low end cut; turning it to the right boosts the low end in the sound.
DIRECT MIX	0–100	Adjusts the volume of the direct sound.
SOLO SW	OFF, ON	The tone to one suitable for solos.
SOLO LEVEL	0–100	Adjusts the volume level when the Solo Sw is ON.

GRAPHIC EQ

STEREO

This adjusts the tone as an equalizer. You can adjust the sound quality in ten bands.

Parameter	Value
31 Hz	-20–+20 dB
62 Hz	
125 Hz	
250 Hz	
500 Hz	
1 kHz	
2 kHz	
4 kHz	
8 kHz	
16 kHz	-20–+20 dB
LEVEL	

PARAMETRIC EQ

STEREO

Adjusts the tonal quality. You can adjust the sound quality in four bands.

Parameter	Value	Explanation
LOW GAIN	-20–+20 dB	Adjusts the low frequency range tone.
HIGH GAIN	-20–+20 dB	Adjusts the high frequency range tone.
LEVEL	-20–+20 dB	Adjusts the overall volume level of the equalizer.
LOW-MID FREQ	20 Hz–10.0 kHz	Specifies the center of the frequency range that will be adjusted by the LOW-MID GAIN.
LOW-MID Q	0.5–16	Adjusts the width of the area affected by the EQ centered at the LOW-MID FREQ. Higher values will narrow the area.
LOW-MID GAIN	-20–+20 dB	Adjusts the low-middle frequency range tone.
HIGH-MID FREQ	20 Hz–10.0 kHz	Specifies the center of the frequency range that will be adjusted by the HIGH-MID GAIN.
HIGH-MID Q	0.5–16	Adjusts the width of the area affected by the EQ centered at the HIGH-MID FREQ. Higher values will narrow the area.
HIGH-MID GAIN	-20–+20 dB	Adjusts the low-middle frequency range tone.
LOW CUT	FLAT, 20 Hz–800 Hz	This sets the frequency at which the low cut filter begins to take effect. When FLAT is selected, the low cut filter will have no effect.
HIGH CUT	630 Hz–12.5 kHz, FLAT	This sets the frequency at which the high cut filter begins to take effect. When FLAT is selected, the high cut filter will have no effect.

TONE MODIFY

MONO

This changes the tone of the connected guitar.

Parameter	Value	Explanation
TYPE	Selects the type of tone modification.	
	FAT	Fat tone with boosted mid range.
	PRES (PRESENCE)	Bright tone with boosted high-mid range.
	MILD	Mild tone with the high end cut back.
	TIGHT	Tone with the low frequencies cut.
	ENHANC (ENHANCE)	Tone with the high frequencies boosted.
	RESO 1–3 (RESONATOR 1–3)	This produces a tone with greater power and punch by adding resonance in the low-frequency range and midrange.
LOW	-50–+50	Adjusts the tone for the low frequency range.
HIGH	-50–+50	Adjusts the tone for the High frequency range.
LEVEL	0–100	Adjusts the volume of the effect sound.
RESO	0–100	This adjusts the strength of the low-end and midrange resonance when TYPE is set to RESO 1, 2, or 3.

EFFECT

GUITAR SIM

MONO

Simulation of the characteristics of particular guitar components such as pickups and different guitar bodies allows you to switch among a number of different guitar types all while using a single guitar.

Parameter	Value	Explanation
TYPE	Selects the type of the guitar simulator.	
	S → H	Changes from a single-coil pickup tone to a humbucking pickup tone.
	H → S	Changes from a humbucking pickup tone to a single-coil pickup tone.
	H → HF	Changes from a humbucking pickup tone to a single-coil pickup half tone.
	S → HLW (HOLLOW)	Changes a single-coil pickup tone to a hollow body tone with the body resonance added.
	H → HLW	Changes a humbucking pickup tone to a hollow body tone with the body resonance added.
	S → AC	Changes a single-coil pickup tone to an acoustic guitar tone.
	H → AC	Changes a humbucking pickup tone to an acoustic guitar tone.
	P → AC	Changes a piezo pickup tone to an acoustic guitar tone.
LOW	-50+50	Adjusts the tone for the low frequency range.
HIGH	-50+50	Adjusts the tone for the High frequency range
LEVEL	0-100	Adjusts the volume of the effect sound.
BODY	0-100	Adjusts the way the body sounds when TYPE is set to S → HLW, H → HLW, S → AC, H → AC or P → AC. The body sound increases as the value is raised; reducing the value produces a tone similar to that from a piezo pickup.

SLOW GEAR

STEREO

This produces a volume-swell effect ("violin-like" sound).

Parameter	Value	Explanation
SENS	0-100	Adjusts the sensitivity of the slow gear. When it is set to a lower value, the effect of the slow gear can be obtained only with a stronger picking, while no effect is obtained with a weaker picking. When the value is set higher, the effect is obtained even with a weak picking.
RISE TIME	0-100	Adjusts the time needed for the volume to reach its maximum from the moment you begin picking.
LEVEL	0-100	Adjusts the volume of the effect sound.

DEFRETTED

MONO

This simulates a fretless guitar.

Parameter	Value	Explanation
SENS	0-100	This controls the input sensitivity of the defretter.
DEPTH	0-100	This controls the rate of the harmonics.
TONE	-50+50	Adjusts the amount of blurring between the notes.
EFFECT LEVEL	0-100	Adjusts the volume of the effect sound.
ATTACK	0-100	Adjusts the attack of the picking sound.
RESO	0-100	Adds a characteristically resonant quality to the sound.
DIRECT MIX	0-100	Adjusts the volume of the direct sound.



WAVE SYNTH

MONO

This is a synth sound that processes the guitar input signal.

* When you use a wave synthesizer, observe the following points.

- Because of the need to analyze the pitch, chords (two or more sounds played simultaneously) cannot be played. Be sure to mute all the other strings and play only one note at a time.
- When you are to play the next string while a certain sound is still playing, mute the previous sound and then play the next one with a clear attack. If the unit cannot detect the attack, it may not sound correctly.
- The sensitivity may vary according to the guitar's TONE knob and pickup type.

Parameter	Value	Explanation
WAVE	Selects a wave type which the synth sound is based.	
	SAW	Creates a synth sound with a saw waveform ().
	SQUARE	Creates a synth sound with the square waveform ().
CUTOFF	0-100	Adjusts the frequency where the harmonics contents of the sound are cut off.
RESO	0-100	This adjusts the amount of resonance (and the tone coloration) in the synth sound. The higher the value, the more the synth tone coloration is emphasized.
FILTER SENS	0-100	This adjusts the amount of filtering applied in response to the input.
FILTER DECAY	0-100	This sets the time needed for the filter to finish its sweep.
FILTER DEPTH	0-100	Adjusts the depth of the filter. When the value is higher, the filter will change more drastically.
SYNTH LEVEL	0-100	Adjusts the volume of the synth sound.
DIRECT MIX	0-100	Adjusts the volume of the direct sound.

SITAR SIM.

MONO

This simulates the sound of the sitar.

Parameter	Value	Explanation
SENS	0–100	Adjusts the sensitivity of the sitar. When it is set to a lower value, no effect of the sitar is obtained with weaker picking, while stronger picking produces the effect. When it is set to a higher value, the effect of the sitar can be obtained whether the picking is weak or strong.
DEPTH	0–100	This adjusts the amount of effect applied.
TONE	-50+50	This adjusts the tone. The high end is boosted as the value increases.
EFFECT LEVEL	0–100	Adjust the volume of the sitar sound.
RESO	0–100	This adjusts the undulation of the resonance.
BUZZ	0–100	Adjusts the amount of characteristic buzz produced by the “buzz bridge” when the strings make contact with it.
DIRECT MIX	0–100	Adjusts the volume of the direct sound.

OCTAVE

MONO

This adds a note one octave lower, creating a richer sound.





Parameter	Value	Explanation
RANGE		This selects the register to which the effect is applied.
	RANGE 1 (B1–E6)	B1 (corresponds to the sound of an open 7th string) to E6 (corresponds to the 1st string played at the 24th fret)
	RANGE 2 (B1–E5)	B1 (corresponds to the sound of an open 7th string) to E5 (corresponds to the 1st string played at the 12th fret)
	RANGE 3 (B1–E4)	B1 (corresponds to the sound of an open 7th string) to E4 (corresponds to the sound of an open 1st string)
	RANGE 4 (B1–E3)	B1 (corresponds to the sound of an open 7th string) to E3 (corresponds to the 4th string played at the 2nd fret)
OCTAVE LEVEL	0–100	Adjusts the volume of the sound one octave below.
DIRECT MIX	0–100	Adjusts the volume of the direct sound.

PITCH SHIFTER

MONO > STEREO

MONO

This effect changes the pitch of the original sound (up or down) within a range of two octaves.







Parameter	Value	Explanation
VOICE		Selects the number of voices for the pitch shift sound.
	1-VOICE 	One-voice pitch-shifted sound output in monaural.
	2-MONO 	Two-voice pitch-shifted sound (PS1, PS2) output in monaural.
	2-STEREO 	Two-voice pitch-shifted sound (PS1, PS2) output through left and right channels.
PS1:PITCH PS2:PITCH	-24+24	Adjusts the amount of pitch shift (the amount of interval) in semitone steps.
DIRECT MIX	0–100	Adjusts the volume of the direct sound.
PS1:MODE PS2:MODE		Selection for the pitch shifter mode.
	FAST, MEDIUM, SLOW	The response is slower in the order of FAST, MEDIUM and SLOW, but the modulation is lessened in the same order.
	MONO	MONO is used for inputting single notes. * You may be unable to produce the intended effect when playing chords (two or more notes played simultaneously).
PS1:FINE PS2:FINE	-50+50	Make fine adjustments to the interval. The amount of the change in the Fine 100 is equivalent to that of the Pitch 1.
PS1:PRE DLY PS2:PRE DLY	0 ms–300 ms, BPM 	Adjusts the time from when the direct sound is heard until the pitch shifted sounds are heard. Normally you can leave this set at 0 ms. * When set to BPM, the value of each parameter will be set according to the value of the “MASTER BPM” specified for each patch. This makes it easier to achieve effect sound settings that match the tempo of the song. * If, due to the tempo, the time is longer than the range of allowable settings, it is then synchronized to a period either 1/2 or 1/4 of that time.
PS1:LEVEL PS2:LEVEL	0–100	Adjusts the volume of the pitch shifter.
PS1:F.BACK	0–100	Adjusts the feedback amount of the pitch shift sound.

HARMONIST

MONO >
STEREO MONO

Harmonist is an effect where the amount of shifting is adjusted according to an analysis of the guitar input, allowing you to create harmony based on diatonic scales.

- * Because of the need to analyze the pitch, chords (two or more sounds played simultaneously) cannot be played.
- * When you are to play the next string while a certain sound is still playing, mute the previous sound and then play the next one with a clear attack. If the unit cannot detect the attack, it may not sound correctly.
- * The sensitivity may vary according to the guitar's TONE knob and pickup type.
- * You cannot use the Harmonist effect with audio input via USB.

Parameter	Value	Explanation
VOICE	1-VOICE 	One-voice pitch-shifted sound output in monaural.
	2-MONO 	Two-voice pitch-shifted sound (HR1, HR2) output in monaural.
	2-STEREO 	Two-voice pitch-shifted sound (HR1, HR2) output through left and right channels.
HR1:HARM HR2:HARM	-2 oct--+2 oct, USER	This determines the pitch of the sound added to the input sound, when you are making a harmony. It allows you to set it by up to 2 octaves higher or lower than the input sound. When the scale is set to USER, this parameter sets the user scale number to be used.
MASTER KEY	C(Am)-B(G#m)	The key setting corresponds to the key of the song (#, b) as follows.  Major C F B ^b E ^b A ^b D ^b Minor Am Dm Gm Cm Fm B ^b m  Major C G D A E B F [#] Minor Am Em Bm F [#] m C [#] m C [#] m D [#] m
HR1:PRE DLY HR2:PRE DLY	0 ms-300 ms, BPM 	Adjusts the time from when the direct sound is heard until the harmonist sounds are heard. Normally you can leave this set at 0 ms. * When set to BPM, the value of each parameter will be set according to the value of the "MASTER BPM" specified for each patch. This makes it easier to achieve effect sound settings that match the tempo of the song. * If, due to the tempo, the time is longer than the range of allowable settings, it is then synchronized to a period either 1/2 or 1/4 of that time.
HR1:F.BACK	0-100	Adjusts the feedback amount of the harmonist sound.
HR1:LEVEL HR2:LEVEL	0-100	Adjusts the volume of the harmony sound.
DIRECT MIX	0-100	Adjusts the volume of the direct sound.

Parameter	Value	Explanation
USER SCALE	C	∇C-∇C-C-▲C-▲C
	Db	∇Db-∇Db-Db-▲Db-▲Db
	D	∇D-∇D-D-▲D-▲D
	Eb	∇Eb-∇Eb-Eb-▲Eb-▲Eb
	E	∇E-∇E-E-▲E-▲E
	F	∇F-∇F-F-▲F-▲F
	F#	∇F#-∇F#-F#-▲F#-▲F#
	G	∇G-∇G-G-▲G-▲G
	Ab	∇Ab-∇Ab-Ab-▲Ab-▲Ab
	A	∇A-∇A-A-▲A-▲A
	Bb	∇Bb-∇Bb-Bb-▲Bb-▲Bb
	B	∇B-∇B-B-▲B-▲B

Specify the note name of the output sound. The minus (-) and plus (+) symbols indicate sounds above or below the set note name. Triangles next to the note names indicate octaves. One downward-pointing triangle indicates a note one octave below the note displayed; two triangles indicates a two-octave drop. One upward-pointing triangle indicates a note one octave above the note displayed; two triangles indicates a two-octave rise.

- * Effective with USER selected for HARM parameter.

SOUND HOLD

MONO

You can have sound played on the guitar be held continuously. This effect allows you to perform the melody in the upper registers while holding a note in the lower registers.

- * This function will not work properly when two or more notes are played simultaneously.

Parameter	Value	Explanation
HOLD	OFF, ON	Switches the hold sound on and off. Normally, this is controlled with the CTL pedals. <ul style="list-style-type: none"> • It is assumed that this parameter will be assigned to the footswitch. • Patches are written with the HOLD parameter set to Off.
RISE TIME	0-100	Adjusts how rapidly the Sound Hold sound is produced.
EFFECT LEVEL	0-120	Adjusts the volume of the hold sound.

AC. PROCESSOR

MONO

This processor allows you to change the sound produced by the pickup on an acoustic electric guitar, creating a richer sound similar to that obtained with a microphone placed close to the guitar.

Parameter	Value	Explanation
TYPE	Selects the modeling type.	
	SMALL	This is the sound of a small-bodied acoustic guitar.
	MEDIUM	This is a standard, unadorned acoustic guitar sound.
	BRIGHT	This is a bright acoustic guitar sound.
	POWER	This is a powerful acoustic guitar sound.
BASS	-50+50	Adjusts the low-end balance.
MIDDLE	-50+50	Adjusts the midrange balance.
MIDDLE FREQ	20.0 Hz–10.0 kHz	Specifies the frequency range to be adjusted with Middle.
TREBLE	-50+50	Adjusts the high-end balance.
PRES	-50+50	Adjusts the balance in the extended upper range.
LEVEL	0–100	Adjusts the volume.

PHASER

MONO

By adding varied-phase portions to the direct sound, the phaser effect gives a whooshing, swirling character to the sound.

Parameter	Value	Explanation
TYPE	Selects the number of stages that the phaser effect will use.	
	4 STAGE	This is a four-phase effect. A light phaser effect is obtained.
	8 STAGE	This is an eight-phase effect. It is a popular phaser effect.
	12 STAGE	This is a twelve-phase effect. A deep phase effect is obtained.
	BiPHASE	This is the phaser with two phase shift circuits connected in series.
RATE	0–100, BPM 	This sets the rate of the phaser effect. * When set to BPM, the value of each parameter will be set according to the value of the "MASTER BPM" specified for each patch. This makes it easier to achieve effect sound settings that match the tempo of the song. * If, due to the tempo, the time is longer than the range of allowable settings, it is then synchronized to a period either 1/2 or 1/4 of that time.
DEPTH	0–100	Determines the depth of the phaser effect.
RESO	0–100	Determines the amount of resonance (feedback). Increasing the value will emphasize the effect, creating a more unusual sound.
MANUAL	0–100	Adjusts the center frequency of the phaser effect.

Parameter	Value	Explanation
STEP RATE	OFF, 0–100, BPM 	This sets the cycle of the step function that changes the rate and depth. When it is set to a higher value, the change will be finer. Set this to "Off" when not using the Step function. * When set to BPM, the value of each parameter will be set according to the value of the "MASTER BPM" specified for each patch. This makes it easier to achieve effect sound settings that match the tempo of the song. * If, due to the tempo, the time is longer than the range of allowable settings, it is then synchronized to a period either 1/2 or 1/4 of that time.
EFFECT LEVEL	0–100	Adjusts the volume of the phaser.
DIRECT MIX	0–100	Adjusts the volume of the direct sound.

FLANGER

STEREO

The flanging effect gives a twisting, jet-airplane-like character to the sound.



Parameter	Value	Explanation
RATE	0–100, BPM 	This sets the rate of the flanging effect. * When set to BPM, the value of each parameter will be set according to the value of the "MASTER BPM" specified for each patch. This makes it easier to achieve effect sound settings that match the tempo of the song. * If, due to the tempo, the time is longer than the range of allowable settings, it is then synchronized to a period either 1/2 or 1/4 of that time.
DEPTH	0–100	Determines the depth of the flanging effect.
RESO	0–100	Determines the amount of resonance (feedback). Increasing the value will emphasize the effect, creating a more unusual sound.
MANUAL	0–100	Adjusts the center frequency at which to apply the effect.
SEPARATION	0–100	Adjusts the diffusion. The diffusion increases as the value increases.
LOW CUT	FLAT, 55 Hz–800 Hz	This sets the frequency at which the low cut filter begins to take effect. When "Flat" is selected, the low cut filter will have no effect.
EFFECT LEVEL	0–100	Adjusts the volume of the flanger.
DIRECT MIX	0–100	Adjusts the volume of the direct sound.

EFFECT

TREMOLO

STEREO





Tremolo is an effect that creates a cyclic change in volume.

Parameter	Value	Explanation
WAVE SHAPE	0–100	Adjusts changes in volume level. A higher value will steepen wave's shape.
RATE	0–100, BPM  	Adjusts the frequency (speed) of the change. * When set to BPM, the value of each parameter will be set according to the value of the "MASTER BPM" specified for each patch. This makes it easier to achieve effect sound settings that match the tempo of the song. * If, due to the tempo, the time is longer than the range of allowable settings, it is then synchronized to a period either 1/2 or 1/4 of that time.
DEPTH	0–100	Adjusts the depth of the effect.
LEVEL	0–100	Adjusts the volume.

ROTARY

MONO
STEREO

This produces an effect like the sound of a rotary speaker.



Parameter	Value	Explanation
SPEED SELECT	SLOW, FAST	This parameter changes the simulated speaker's rotating speed (SLOW or FAST).
RATE-SLOW	0–100, BPM  	This parameter adjusts the SPEED SELECT of rotation when set to "SLOW."
RATE-FAST	0–100, BPM  	This parameter adjusts the SPEED SELECT of rotation when set to "FAST." * When set to BPM, the value of each parameter will be set according to the value of the "MASTER BPM" specified for each patch. This makes it easier to achieve effect sound settings that match the tempo of the song. * If, due to the tempo, the time is longer than the range of allowable settings, it is then synchronized to a period either 1/2 or 1/4 of that time.
DEPTH	0–100	This parameter adjusts the amount of depth in the rotary effect.
RISE TIME	0–100	This parameter adjusts the time it takes for the rotation SPEED SELECT to change when switched from "SLOW" to "FAST."
FALL TIME	0–100	This parameter adjusts the time it takes for the rotation SPEED SELECT to change when switched from "FAST" to "SLOW."
LEVEL	0–100	Adjusts the volume.

UNI-V

MONO

This models a Uni-Vibe.



Although this resembles a phaser effect, it also provides a unique undulation that you can't get with a regular phaser.

Parameter	Value	Explanation
RATE	0–100, BPM  	Adjusts the rate of the UNI-V effect. * When set to BPM, the value of each parameter will be set according to the value of the "MASTER BPM" specified for each patch. This makes it easier to achieve effect sound settings that match the tempo of the song. * If, due to the tempo, the time is longer than the range of allowable settings, it is then synchronized to a period either 1/2 or 1/4 of that time.
DEPTH	0–100	Adjusts the depth of the UNI-V effect.
LEVEL	0–100	Adjusts the volume.

PAN

STEREO

With the volume level of the left and right sides alternately changing, when playing sound in stereo, you can get an effect that makes the guitar sound appear to fly back and forth between the speakers.

Parameter	Value	Explanation
TYPE	AUTO	This varies the volume level on the left and right according to the settings for WAVE SHAPE, RATE, and DEPTH.
	MANUAL	Output uses the volume balance set with POS.
WAVE SHAPE *1	0–100	Adjusts changes in volume level. A higher value will steepen wave's shape.
RATE *1	0–100, BPM  	Adjusts the frequency (speed) of the change. * When set to BPM, the value of each parameter will be set according to the value of the "MASTER BPM" specified for each patch. This makes it easier to achieve effect sound settings that match the tempo of the song. * If, due to the tempo, the time is longer than the range of allowable settings, it is then synchronized to a period either 1/2 or 1/4 of that time.
DEPTH *1	0–100	Adjusts the depth of the effect.
POS *2	L 100–CENTER– R 100	This adjusts the volume balance between the left and right channels.
LEVEL	0–100	Adjusts the volume.

*1 Setting available when TYPE is set to AUTO.

*2 Setting available when TYPE is set to MANUAL.

SLICER

STEREO

This consecutively interrupts the sound to create the impression that a rhythm backing phrase is being played.

Parameter	Value	Explanation
PATTERN	P1-P20	Select the slice pattern that will be used to cut the sound.
RATE	0-100, BPM 	Adjust the rate at which the sound will be cut. * When set to BPM, the value of each parameter will be set according to the value of the "MASTER BPM" specified for each patch. This makes it easier to achieve effect sound settings that match the tempo of the song. * If, due to the tempo, the time is longer than the range of allowable settings, it is then synchronized to a period either 1/2 or 1/4 of that time.
TRIGGER SENS	0-100	Adjust the sensitivity of triggering. With low settings of this parameter, softly picked notes will not retrigger the phrase (i.e., the phrase will continue playing), but strongly picked notes will retrigger the phrase so that it will playback from the beginning. With high settings of this parameter, the phrase will be retriggered even by softly picked notes.
EFFECT LEVEL	0-100	Adjusts the volume of the effect sound.
DIRECT MIX	0-100	Adjusts the volume of the direct sound.

VIBRATO

STEREO

This effect creates vibrato by slightly modulating the pitch.

Parameter	Value	Explanation
RATE	0-100, BPM 	Adjusts the rate of the vibrato. * When set to BPM, the value of each parameter will be set according to the value of the "MASTER BPM" specified for each patch. This makes it easier to achieve effect sound settings that match the tempo of the song. * If, due to the tempo, the time is longer than the range of allowable settings, it is then synchronized to a period either 1/2 or 1/4 of that time.
DEPTH	0-100	Adjusts the depth of the vibrato.
TRIGGER	OFF, ON	This selects on/off of the vibrato. * It is assumed that this parameter will be assigned to the footswitch.
RISE TIME	0-100	This sets the time passing from the moment the Trigger is turned on until the set vibrato is obtained. * When a patch with TRIGGER set to ON is called up, the effect obtained is identical to what happens when TRIGGER is switched from Off to On. If you want the vibrato effect to be produced immediately after the patches are switched, set RISE TIME to 0.
LEVEL	0-100	Adjusts the volume.

RING MOD.

STEREO

This creates a bell-like sound by ring-modulating the guitar sound with the signal from the internal oscillator. The sound can be unmusical and lack distinctive pitches.

Parameter	Value	Explanation
MODE		This selects the mode for the ring modulator.
	NORMAL	This is a normal ring modulator.
	INTELLIGENT	By ring-modulating the input signal, a bell like sound is created. The intelligent ring modulator changes the oscillation frequency according to the pitch of the input sound and therefore produces a sound with the sense of pitch, which is quite different from NORMAL. This effect does not give a satisfactory result if the pitch of the guitar sound is not correctly detected. So, you must use single notes, not chords.
FREQUENCY	0-100	Adjusts the frequency of the internal oscillator.
EFFECT LEVEL	0-100	Adjusts the volume of the effect sound.
DIRECT MIX	0-100	Adjusts the volume of the direct sound.

HUMANIZER

MONO

This can create human vowel-like sounds.

Parameter	Value	Explanation
MODE		This sets the mode that switches the vowels.
	PICKING	It changes from VOWEL 1 to VOWEL 2 along with the picking. The time spent for the change is adjusted with the rate.
	AUTO	By adjusting the rate and depth, two vowels (VOWEL 1 and VOWEL 2) can be switched automatically.
VOWEL 1	a, e, i, o, u	Selects the first vowel.
VOWEL 2	a, e, i, o, u	Selects the second vowel.
SENS *1	0-100	Adjusts the sensitivity of the humanizer. When it is set to a lower value, no effect of the humanizer is obtained with weaker picking, while stronger picking produces the effect. When it is set to a higher value, the effect of the humanizer can be obtained whether the picking is weak or strong.
RATE	0-100, BPM 	Adjusts the cycle for changing the two vowels. * When set to BPM, the value of each parameter will be set according to the value of the "MASTER BPM" specified for each patch. This makes it easier to achieve effect sound settings that match the tempo of the song. * If, due to the tempo, the time is longer than the range of allowable settings, it is then synchronized to a period either 1/2 or 1/4 of that time.
DEPTH	0-100	Adjusts the depth of the effect.
MANUAL *2	0-100	This determines the point where the two vowels are switched. When it is set to 50, VOWEL 1 and VOWEL 2 are switched in the same length of time. When it is set to lower than 50, the time for VOWEL 1 is shorter. When it is set to higher than 50, the time for VOWEL 1 is longer.
LEVEL	0-100	Adjusts the volume.



*1 Setting available when MODE is set to PICKING.

*2 Setting available when MODE is set to AUTO.

2X2 CHORUS

MONO
STEREO

Frequency band division is employed to produce two different choruses, one for low frequencies and one for higher frequencies, for both the left and right channels (for a total of four). This allows you to achieve a more natural chorus sound.



Parameter	Value	Explanation
LOW RATE	0–100, BPM 	Adjust the speed of the chorus effect for the low frequency range. * When set to BPM, the value of each parameter will be set according to the value of the "MASTER BPM" specified for each patch. This makes it easier to achieve effect sound settings that match the tempo of the song. * If, due to the tempo, the time is longer than the range of allowable settings, it is then synchronized to a period either 1/2 or 1/4 of that time.
LOW DEPTH	0–100	Adjust the depth of the chorus effect for the low frequency range. If you wish to use this as a doubling effect, use a setting of 0.
HIGH RATE	0–100, BPM 	Adjust the speed of the chorus effect for the high frequency range. * When set to BPM, the value of each parameter will be set according to the value of the "MASTER BPM" specified for each patch. This makes it easier to achieve effect sound settings that match the tempo of the song. * If, due to the tempo, the time is longer than the range of allowable settings, it is then synchronized to a period either 1/2 or 1/4 of that time.
HIGH DEPTH	0–100	Adjust the depth of the chorus effect for the high frequency range. If you wish to use this as a doubling effect, use a setting of 0.
LOW PRE DELAY	0.0 ms–40.0 ms	Adjusts the delay of the effect sound in the low-frequency range. Extending the pre-delay will produce the sensation of multiple sounds (doubling effect).
LOW LEVEL	0–100	Adjusts the volume of the effect sound in the low-frequency range.
HIGH PRE DELAY	0.0 ms–40.0 ms	Adjusts the delay of the effect sound in the high-frequency range. Extending the pre-delay will produce the sensation of multiple sounds (doubling effect).
HIGH LEVEL	0–100	Adjusts the volume of the effect sound in the high-frequency range.
XOVER FREQ	100 Hz–4.00 kHz	This sets the frequency dividing the low- and high-frequency ranges.

SUB DELAY

MONO
STEREO

MONO

This is a delay with the maximum delay time of 1,000 ms. This effect is useful for making the sound fatter.



Parameter	Value	Explanation
TYPE	Use this to choose the type of delay.	
	MONO 	A simple monaural delay.
	PAN 	Provides a tap delay effect that divides the delay time between the left and right channels.
DELAY TIME	1 ms–1000 ms, BPM 	Adjusts the delay time. * When set to BPM, the value of each parameter will be set according to the value of the "MASTER BPM" specified for each patch. This makes it easier to achieve effect sound settings that match the tempo of the song. * If, due to the tempo, the time is longer than the range of allowable settings, it is then synchronized to a period either 1/2 or 1/4 of that time.
F.BACK	0–100	Adjusts the volume that is returned to the input. Higher settings will result in more delay repeats.
EFFECT LEVEL	0–120	Adjusts the volume of the delay sound.
HIGH CUT	630 Hz–12.5 kHz, FLAT	This sets the frequency at which the high cut filter begins to take effect. When "FLAT" is selected, the high cut filter will have no effect.
TAP TIME *1	0–100%	Adjusts the delay time of the left channel delay. This setting adjusts the L channel delay time relative to the R channel delay time (considered as 100%).
DIRECT MIX	0–100	Adjusts the volume of the direct sound.

*1 Setting available when TYPE is set to PAN.

DELAY

STEREO MONO MONO

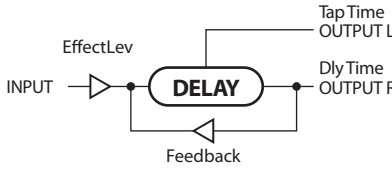
This effect adds delayed sound to the direct sound, giving more body to the sound or creating special effects.

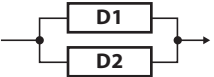
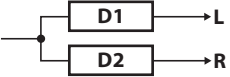
Parameter	Value	Explanation
DELAY ON/OFF	OFF, ON	Turns this effect on/off.
TYPE	This selects which type of delay. * If you switch patches with the Type set to either DUAL-S, DUAL-P, or DUAL-L/R and then begin to play immediately after the patches change, you may be unable to attain the intended effect in the first portion of what you perform. * The stereo effect is cancelled if a monaural effect or COSM amp is connected after a stereo delay effect.*	
	SINGLE	This is a simple monaural delay.
	PAN	This delay is specifically for stereo output. This allows you to obtain the tap delay effect that divides the delay time, then deliver them to L and R channels. 
	STEREO	The direct sound is output from the left channel, and the effect sound is output from the right channel.
	DUAL-S	This is a delay comprising two different delays connected in series. Each delay time can be set in a range from 1 ms to 1000 ms. 
	DUAL-P	This is a delay comprising two delays connected in parallel. Each delay time can be set in a range from 1 ms to 1000 ms. 
	DUAL-L/R	This is a delay with individual settings available for the left and right channels. Delay 1 goes to the left channel, Delay 2 to the right. 
	REVERSE	This produces an effect where the sound is played back in reverse.
	ANALOG	This gives a mild analog delay sound. The delay time can be set within the range of 1 to 2000 ms.
	TAPE	This setting provides the characteristic wavering sound of the tape echo. The delay time can be set within the range of 1 to 3400 ms.
MOD (MODULATE)	This delay adds a pleasant wavering effect to the sound.	

COMMON

Parameter	Value	Explanation
DELAY TIME	1 ms–2000 ms, BPM	This determines the delay time. * When set to BPM, the value of each parameter will be set according to the value of the "MASTER BPM" specified for each patch. This makes it easier to achieve effect sound settings that match the tempo of the song. * If, due to the tempo, the time is longer than the range of allowable settings, it is then synchronized to a period either 1/2 or 1/4 of that time.
F.BACK	0–100	This sets the amount of delay sound returned to the input. A higher value will increase the number of the delay repeats.
HIGH CUT	630 Hz–12.5 kHz, FLAT	This sets the frequency at which the high cut filter begins to take effect. When "Flat" is selected, the high cut filter will have no effect.
EFFECT LEVEL	0–120	Adjusts the volume of the delay sound.
DIRECT MIX	0–100	Adjusts the volume of the direct sound.

PAN

Parameter	Value	Explanation
TAP TIME	0–100%	Adjusts the delay time of the left channel delay. This setting adjusts the L channel delay time relative to the R channel delay time (considered as 100%).

DUAL-S, DUAL-P, DUAL-L/R

Parameter	Value	Explanation
D1:TIME D2:TIME	1 ms–1000 ms, BPM	This determines the delay time. * When set to BPM, the value of each parameter will be set according to the value of the "MASTER BPM" specified for each patch. This makes it easier to achieve effect sound settings that match the tempo of the song. * If, due to the tempo, the time is longer than the range of allowable settings, it is then synchronized to a period either 1/2 or 1/4 of that time.
D1:F.BACK D2:F.BACK	0–100	Adjusts the amount of feedback of the DELAY 1 (or DELAY 2). A higher value will increase the number of the delay repeats.
D1:HI CUT D2:HI CUT	630 Hz–12.5 kHz, FLAT	This sets the frequency at which the high cut filter begins to take effect. When "FLAT" is selected, the high cut filter will have no effect.
D1:LEVEL D2:LEVEL	0–120	Adjusts the volume of the DELAY 1 (or DELAY 2).

EFFECT

MODULATE

Parameter	Value	Explanation
MOD RATE	0–100	Adjusts the modulation rate of the delay sound.
MOD DEPTH	0–100	Adjusts the modulation depth of the delay sound.

CHORUS



In this effect, a slightly detuned sound is added to the original sound to add depth and breadth.

Parameter	Value	Explanation
CHORUS ON/OFF	OFF, ON	Turns this effect on/off.
MODE	Selection for the chorus mode.	
	MONO	This chorus effect outputs the same sound from both L channel and R channel.
	STEREO 1	This is a stereo chorus effect that adds different chorus sounds to L channel and R channel.
	STEREO 2	This stereo chorus uses spatial synthesis, with the direct sound output in the L channel and the effect sound output in the R channel.
RATE	0–100, BPM	Adjusts the rate of the chorus effect. * When set to BPM, the value of each parameter will be set according to the value of the "MASTER BPM" specified for each patch. This makes it easier to achieve effect sound settings that match the tempo of the song. * If, due to the tempo, the time is longer than the range of allowable settings, it is then synchronized to a period either 1/2 or 1/4 of that time.
DEPTH	0–100	Adjusts the depth of the chorus effect. * To use it for doubling effect, set the value to 0.
EFFECT LEVEL	0–100	Adjusts the volume of the effect sound.
PRE DELAY	0.0 ms–40.0 ms	Adjusts the time needed for the effect sound to be output after the direct sound has been output. By setting a longer pre delay time, you can obtain an effect that sounds like more than one sound is being played at the same time (doubling effect).
LOW CUT	FLAT, 20 Hz–800 Hz	This sets the frequency at which the low cut filter begins to take effect. When "Flat" is selected, the low cut filter will have no effect.
HIGH CUT	630 Hz–12.5 kHz, FLAT	This sets the frequency at which the high cut filter begins to take effect. When "Flat" is selected, the high cut filter will have no effect.

REVERB



This effect adds reverberation to the sound.

Parameter	Value	Explanation	
REVERB ON/OFF	OFF, ON	Turns this effect on/off.	
TYPE	This selects the reverb type. Various different simulations of space are offered.		
	AMBIENC (AMBIENCE)	Simulates an ambience mic (off-mic, placed at a distance from the sound source) used in recording and other applications. Rather than emphasizing the reverberation, this reverb is used to produce a sense of openness and depth.	
	ROOM	Simulates the reverberation in a small room. Provides warm reverberations.	
	HALL 1	Simulates the reverberation in a concert hall. Provides clear and spacious reverberations.	
	HALL 2	Simulates the reverberation in a concert hall. Provides mild reverberations.	
	PLATE	Simulates plate reverberation (a reverb unit that uses the vibration of a metallic plate). Provides a metallic sound with a distinct upper range.	
	SPRING	This simulates the sound of a guitar amp's built-in spring reverb.	
	MOD (MODULATE)	This reverb adds the wavering sound found in hall reverb to provide an extremely pleasant reverb sound.	
	REV TIME	0.1 s–10.0 s	Adjusts the length (time) of reverberation.
	PRE DELAY	0 ms–500 ms	Adjusts the time until the reverb sound appears.
EFFECT LEVEL	0–100	Adjusts the volume of the reverb sound.	
LOW CUT	FLAT, 20 Hz–800 Hz	This sets the frequency at which the low cut filter begins to take effect. When "Flat" is selected, the low cut filter will have no effect.	
HIGH CUT	630 Hz–12.5 kHz, FLAT	This sets the frequency at which the high cut filter begins to take effect. When "Flat" is selected, the high cut filter will have no effect.	
DENSITY	0–10	Adjusts the density of the reverb sound.	
DIRECT MIX	0–100	Adjusts the volume of the direct sound.	
SPRING SENS (TYPE = SPRING only)	0–100	Adjusts the sensitivity of the spring effect. When the value is set higher, the effect is obtained even with a weak picking.	

PEDAL FX

PEDAL BEND

MONO

This lets you use the pedal to get a pitch bend effect.

* Because of the need to analyze the pitch, chords (two or more sounds played simultaneously) cannot be played.

Parameter	Value	Explanation
PITCH	-24--+24	This sets the pitch at the point where the EXP Pedal is all the way down.
PEDAL POS	0-100	Adjusts the pedal position for pedal bend. This parameter is used after it's been assigned to an EXP Pedal or similar controller.
EFFECT LEVEL	0-100	Adjusts the volume of the pitch bend sound.
DIRECT MIX	0-100	Adjusts the volume of the direct sound.

WAH

MONO

You can control the wah effect in real time by adjusting the [EXP] pedal or the expression pedal connected to the SUB CTL 1, 2/SUB EXP jack.

Parameter	Value	Explanation
TYPE		Selects the type of wah.
	CRY WAH	This models the sound of the CRY BABY wah pedal popular in the '70s.
	VO WAH	This models the sound of the VOX V846.
	FAT WAH	This is a wah sound featuring a bold tone.
	LIGHT WAH	This wah has a refined sound with no unusual characteristics.
	7STRING WAH	This expanded wah features a variable range compatible with seven-string and baritone guitars.
	RESO WAH	This completely original effect offers enhancements on the characteristic resonances produced by analog synth filters.
PEDAL POS	0-100	Adjusts the position of the wah pedal. * This parameter is used after it's been assigned to an EXP Pedal or similar controller.
PEDAL MIN	0-100	Selects the tone produced when the heel of the EXP Pedal is depressed.
PEDAL MAX	0-100	Selects the tone produced when the toe of the EXP Pedal is depressed.
EFFECT LEVEL	0-100	Adjusts the volume of the effect sound.
DIRECT MIX	0-100	Adjusts the volume of the direct sound.

FOOT VOLUME

FOOT VOLUME

STEREO

This is a volume control effect.

Normally, this is controlled with the EXP Pedal or the [EXP] pedal connected to the SUB CTL 1, 2/SUB EXP jack.

Parameter	Value	Explanation
VOLUME MIN	0-100	Sets the volume when the heel of the EXP Pedal is depressed.
VOLUME MAX	0-100	Selects the volume when the toe of the EXP Pedal is depressed.
VOLUME CURVE	SLOW 1, SLOW 2, NORMAL, FAST	<p>You can select how the actual volume changes relative to the amount the pedal is pressed.</p> <p>When the pedal is fully raised</p> <p>When the pedal is fully advanced</p>
LEVEL	0-100	Adjusts the volume.

DIVIDER

STEREO

Within the effect chain, the point where the signal is split into channels "A" and "B" is called the "divider," and the point where the two signals are recombined is called the "mixer."

You can use the divider to switch between channels "A" and "B," to assign strongly picked notes and softly picked notes to different channels, or to assign different frequency bands of your guitar sound to different channels.

The mixer lets you adjust the volume balance of channels "A" and "B," place them in the stereo field, or slightly delay the sound of channel "B" to produce a spacious sound.

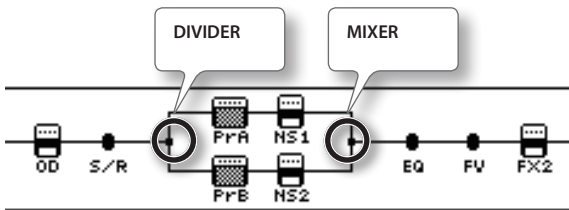

Parameter	Value	Explanation
MODE	SINGLE	Use only one channel, either "A" or "B."
	DUAL	Use the two channels "A" and "B."

SINGLE

Parameter	Value	Explanation
CH SELECT	Ch. A, Ch. B	Selects the channel to use.

DUAL Ch. A, DUAL Ch. B

Parameter	Value	Explanation
Ch. A/Ch. B DYNAMIC	OFF	DYNAMIC will not be used.
	POLAR+	Only notes picked more strongly than the DYNAMIC SENS setting will be output.
	POLAR-	Only notes picked more softly than the DYNAMIC SENS setting will be output.
Ch. A/Ch. B DYNAMIC SENS	0-100	Specifies the picking sensitivity.
Ch. A/Ch. B FILTER	OFF	The filter will not be used.
	LPF	Only the region below the cutoff frequency will be output.
	HPF	Only the region above the cutoff frequency will be output.
Ch. A/Ch. B CUTOFF FREQ	100 Hz-2 kHz	Cutoff frequency

MIXER

STEREO

Parameter	Value	Explanation
MODE	STEREO	Channels "A" and "B" will be mixed and output in stereo.
	PAN L/R	Channels "A" and "B" will be assigned respectively to the L and R OUTPUT jacks.
CH A/B BALANC	100:0-0:100	Adjusts the volume balance of channels "A" and "B." * This is shown only if DIVIDER MODE is set to "DUAL."
SPREAD	0-100	Slightly delays the sound of channel "B" to make the sound more spacious. * This is shown only if DIVIDER MODE is set to "DUAL."

SEND/RETURN

MONO

You can connect an external effects processor between the SEND jack and RETURN jack, and use it as one of the GT-100's effects processors.

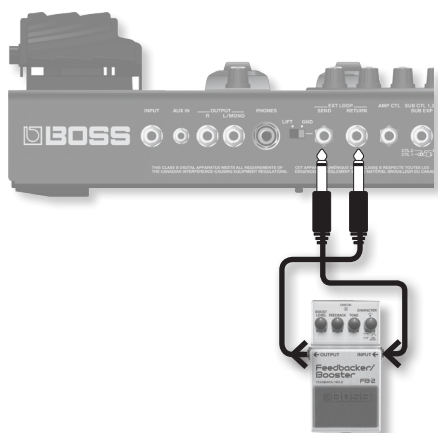

The sound that is input to SEND/RETURN within the effect chain will be output to the SEND jack. The sound that is input via the RETURN jack will be input to SEND/RETURN within the effect chain.

Parameter	Value	Explanation
SEND/RETURN ON/OFF	OFF, ON	Turns the SEND/RETURN on/off.
MODE	NORMAL	<p>The input to SEND/RETURN within the effect chain will be output to the SEND jack, and the input from the RETURN jack will be output following SEND/RETURN.</p> <p>Use this setting if you want to connect an external effects processor in series within the GT-100's effect chain.</p>
	DIRECT MIX	<p>The input to SEND/RETURN within the effect chain will be output to the SEND jack, and the input from the RETURN jack and the input to SEND/RETURN (the direct sound) will be mixed and output following SEND/RETURN.</p> <p>Use this when you want to mix the GT-100's effects sounds together with the sound with the external effects device applied to it.</p>
	BRANCH OUT	<p>The input to SEND/RETURN within the effect chain will be output to the SEND jack. The input from the RETURN jack will be ignored.</p> <p>For example, by placing SEND/RETURN in front of reverb or delay, this allows you to use the SEND jack as a dry out.</p>
SEND LEVEL	0-200	Adjusts the volume of the output to the external effects device.
RETURN LEVEL	0-200	Adjusts the volume of the input from the external effects device.

NS1/NS2

STEREO

This effect reduces the noise and hum picked up by guitar pickups. Since it suppresses the noise in synchronization with the envelope of the guitar sound (the way in which the guitar sound decays over time), it has very little effect on the guitar sound, and does not harm the natural character of the sound.

Parameter	Value	Explanation
NS ON/OFF	OFF, ON	Switches the noise suppressor effect on/off.
THRESH	0-100	<p>Adjust this parameter as appropriate for the volume of the noise. If the noise level is high, a higher setting is appropriate. Adjust this value until the decay of the guitar sound is as natural as possible.</p> <p>* High settings for the threshold parameter may result in there being no sound when you play with your guitar volume turned down.</p>
RELEASE	0-100	Adjusts the time from when the noise suppressor begins to function until the noise level reaches "0."
DETECT	This controls the noise suppressor based on the volume level for the point specified in Detect.	
	INPUT	<p>Input volume from input jack.</p> <p>* Ordinarily, DETECT should be set to "INPUT."</p>
	NS INPUT	<p>Noise suppressor input volume.</p> <p>* When connected as illustrated below, and you want to prevent a spatial-type effects sound (such as a delay sound) from being eradicated by the NS, you should set DETECT to "NS INPUT."</p>
FV OUT	<p>Volume after passing through Foot Volume.</p> <p>* If you want to use FV (Foot Volume) in place of the guitar's volume control, you need to set DETECT to "FV OUT."</p>	

EFFECT

ACCEL FX

This allows for the use of six different types of Accel effects, which modify the sound over time when you depress the [ACCEL/CTL] pedal.

Parameter	Value	Explanation
TYPE	S-BEND	Applies intense bending.
	LASER BEAM	Produces a laser beam-like sound.
	RING MOD.	Produces a metallic sound, creating the impression that the sound is being focused.
	TWIST	Produces an aggressive sense of rotation. Using this in conjunction with distortion will produce an even wilder sense of rotation.
	WARP	Produces a dream-like sound.
	FEEDBACKER	Generates feedback performance.

S-BEND

MONO

Applies intense bending.

Parameter	Value	Explanation
PITCH	-3 oct, -2 oct, -1 oct, +1 oct, +2 oct, +3 oct, +4 oct	Adjusts the amount of pitch shift in octave steps.
RISE TIME	0-100	This parameter adjusts the amount of time it is to take for the effect to transition to the maximum.
FALL TIME	0-100	This parameter adjusts the amount of time it is to take for the effect to transition to the original.

LASER BEAM

STEREO

Produces a laser beam-like sound.

Parameter	Value	Explanation
RATE	0-100	Adjusts the modulation rate of the sound.
DEPTH	0-100	Adjusts the modulation depth of the sound.
RISE TIME	0-100	This parameter adjusts the amount of time it is to take for the effect to transition to the maximum.
FALL TIME	0-100	This parameter adjusts the amount of time it is to take for the effect to transition to the original.

RING MOD.

STEREO

Produces a metallic sound, creating the impression that the sound is being focused.

Parameter	Value	Explanation
FREQ	0-100	Adjusts the frequency of the internal oscillator.
RISE TIME	0-100	This parameter adjusts the amount of time it is to take for the effect to transition to the maximum.
FALL TIME	0-100	This parameter adjusts the amount of time it is to take for the effect to transition to the original.
RING LEVEL	0-100	Adjusts the volume of the effect sound.
OCTAVE LEVEL	0-100	Adjusts the volume of the one octave low sound.
DIRECT MIX	0-100	Adjusts the volume of the direct sound.

TWIST

STEREO

Produces an aggressive sense of rotation. Using this in conjunction with distortion will produce an even wilder sense of rotation.

Parameter	Value	Explanation
RISE TIME	0-100	This parameter adjusts the amount of time it is to take for the effect to transition to the maximum.
FALL TIME	0-100	This parameter adjusts the amount of time it is to take for the effect to transition to the original.
LEVEL	0-100	Adjusts the volume of the effect sound.

WARP

STEREO

Produces a dream-like sound.

Parameter	Value	Explanation
RISE TIME	0-100	This parameter adjusts the amount of time it is to take for the effect to transition to the maximum.
FALL TIME	0-100	This parameter adjusts the amount of time it is to take for the effect to transition to the original.
LEVEL	0-100	Adjusts the volume of the effect sound.

FEEDBACKER

MONO

Generates feedback performance.

* Note that the notes you want to apply feedback to must be played singly and cleanly.

Parameter	Value	Explanation
MODE	NORMAL	Analyzes the pitch of the guitar sound being input, and then creates a feedback sound.
	OSC	An artificial feedback sound will be created internally. When OSC is selected, the effect is activated after a single note is played and the note stabilizes. A feedback effect is created when the effect switches on; the feedback disappears when the OSC effect switches off.
DEPTH *1	0-100	Adjusts the ease with which feedback will occur when the FEEDBACKER is on.
RISE TIME *2	0-100	This determines the time needed for the volume of the feedback sound to reach its maximum from the moment the effect is turned on.
OCTAVE RISE TIME *2	0-100	This determines the time needed for the volume of the one octave higher feedback sound to reach its maximum from the moment the effect is turned on.
F.BACK LEVEL *2	0-100	Adjusts the volume of the feedback sound.
OCTAVE F.BACK LEVEL *2	0-100	Adjusts the volume of the one octave higher feedback sound.
VIB RATE *2	0-100	Adjusts the rate of the vibrato when the FEEDBACKER is on.
VIB DEPTH *2	0-100	Adjusts the depth of the vibrato when the FEEDBACKER is on.

*1 MODE=NORMAL only

*2 MODE=OSC only

MASTER SETTING

These settings are applied to the overall patch.

MASTER SETTING

Parameter	Value	Explanation
PATCH LEVEL	0–200	Adjusts the volume of the patch.
MASTER BPM	40–250	Adjusts the BPM value for each patch. * BPM (beats per minute) indicates the number of quarter note beats that occur each minute. * When you have an external MIDI device connected, the MASTER BPM synchronizes to the external MIDI device's tempo, making it impossible to set the MASTER BPM. To enable setting of the MASTER BPM, set "SYNC CLOCK" (p. 29) to INTERNAL.
MASTER KEY	C (Am)–B (G#m)	This sets the key for the FX HARMONIST. Major C F B ^b E ^b A ^b D ^b Minor Am Dm Gm Cm Fm B ^b m Major C G D A E B F [#] Minor Am Em Bm F [#] m C [#] m G [#] m D [#] m

MASTER EQ

STEREO

Parameter	Value	Explanation
MASTER LOW GAIN	-20–+20 dB	Adjusts the low frequency range tone.
MASTER HIGH GAIN	-20–+20 dB	Adjusts the high frequency range tone.
MASTER MID FREQ	20.0 Hz–10.0 kHz	Specify the center of the frequency range that will be adjusted by the MASTER MID GAIN.
MASTER MID Q	0.5–16	Adjusts the width of the area affected by the EQ centered at the MASTER MID FREQ. Higher values will narrow the area.
MASTER MID GAIN	-20–+20 dB	Adjusts the middle frequency range tone.

AMP CONTROL

By connecting your guitar amp's channel switching jack to the GT-100's AMP CONTROL jack, you can then use Amp Control to switch the amp channel.

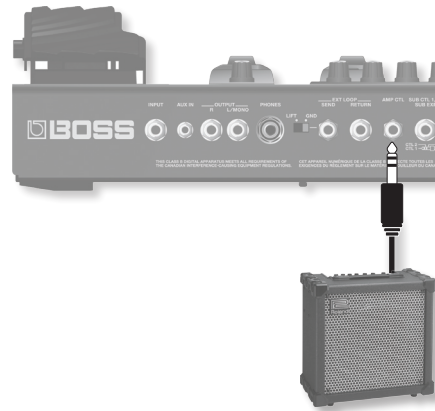

This combining of the GT-100 and the amp channels allows you to get an even wider variety of distortion sounds. Since the Amp Control setting is handled as one of the effects parameters saved to each individual patch, it allows you to switch guitar amp channels with each patch.

Parameter	Value	Explanation
AMP CONTROL	OFF	GT-100 (AMP CONTROL jack) Guitar Amp (Channel switching jack)
	ON	GT-100 (AMP CONTROL jack) Guitar Amp (Channel switching jack)

* To determine how the amp channels are switched when the circuit is open and shorted, refer to the amp owner's manual, or actually confirm the sounds by operating the amp.

* Note that, depending on the circuitry of the channel switching jack in the guitar amp used, the Amp Control function may not operate.

* Since this is a single mono plug, it can't switch a three-channel amp.

MEMO

With Amp Control, not only can you switch amp channels, you can also use it to switch the amp's effects on and off, like a footswitch controller.

OUTPUT SELECT

Specify the device (amp) that's connected to the OUTPUT jacks.

Parameter	Value	Explanation
SELECT	JC-120	Choose this setting if the GT-100 is connected to the guitar input of a Roland JC-120 guitar amp.
	SMALL AMP	Choose this setting if the GT-100 is connected to a small guitar amp.
	COMBO AMP	Choose this setting if the GT-100 is connected to the guitar input of a combo-type guitar amp (i.e., a single unit that contains the amp and speaker) other than the JC-120. For some types of guitar amps, the "JC-120" setting might produce better results.
	STACK AMP	Choose this setting if the GT-100 is connected to the guitar input of a stack-type guitar amp (i.e., one in which the amp and speaker are separate units).
	JC-120 RETURN	Choose this setting if the GT-100 is connected to the RETURN jack of the JC-120.
	COMBO RETURN	Choose this setting if the GT-100 is connected to the RETURN jack of a combo-type guitar amp.
	STACK RETURN	Choose this setting if the GT-100 is connected to the RETURN jack of a stack-type guitar amp. You should also choose the "STACK RETURN" setting if you're using a guitar power amp together with a speaker cabinet.
	LINE/PHONES	Choose this setting if you're using headphones, or if the GT-100 is connected to a keyboard amp, mixer, or digital recorder.

INPUT

Adjust the input level according to the output level of the guitar that you've connected.

Parameter	Value	Explanation
INPUT LEVEL	-20+20 dB	Adjusts the guitar input level.

GLOBAL EQ

STEREO

This adjusts the tone of the OUTPUT regardless of the equalizer on/off settings of individual patches.

Parameter	Value	Explanation
LOW GAIN	-20+20 dB	Adjusts the low frequency range tone.
MID GAIN	-20+20 dB	Adjusts the middle frequency range tone.
MID FREQ	20.0 Hz–10.0 kHz	Specifies the center of the frequency range that will be adjusted by the MID GAIN.
MID Q	0.5–16	Adjusts the width of the area affected by the EQ centered at the MID FREQ. Higher values will narrow the area.
HIGH GAIN	-20+20 dB	Adjusts the high frequency range tone.

TOTAL

These parameters control the threshold level of the noise suppressor used by each patch, the overall reverb level, and the overall output. They do not affect the settings of each patch.



Parameter	Value	Explanation
NS THRESH	-20+20 dB	Control the threshold level of the noise suppressor used by each patch. This does not affect the settings of each patch. * If you want to use the settings specified for each patch, set this to 0 dB.
REVERB	0–200%	Adjusts the reverb level specified for each patch. It is useful to adjust the reverb level appropriately for the space in which you're performing. This does not affect the settings of each patch. * If you want to use the settings specified for each patch, set this to 100 %.
MAIN OUTPUT LEVEL	-10 dB, +4 dB	Specifies the output reference level as appropriate for the input level of the device connected to the OUTPUT jacks.

PHRASE LOOP

STEREO

MONO

Here are various settings for the Phrase Loop function.

Parameter	Value	Explanation
MODE	PERFORM	The sound processed by the effects will be recorded. This lets you create a variety of performances by layering different sounds.
	PATCH EDIT	The sound before being processed by the effects will be recorded, and the effects will be applied when the loop is played back. This is a convenient way to adjust the effects, or to compare the sound of different patches.
REC MODE	MONO 	The phrase will be recorded in monaural (maximum 38 seconds).
	STEREO 	The phrase will be recorded in stereo (maximum 19 seconds).
PLAY LEVEL	0–120	Specifies the phrase playback volume.
PEDAL FUNC	OFF	Phrase Loop will not operate even if you press the [PHRASE LOOP] pedal.
	PHRASE LOOP	You can use the [PHRASE LOOP] pedal to switch Phrase Loop on/off or to record.

PLAY OPTION

Here you can specify how the pedals will work during performance.

Parameter	Value	Explanation
BANK CHANGE MODE	WAIT	Although the indication in the display is updated to reflect the change in the bank when a BANK pedal is pressed, the patch will not change until a number pedal has been pressed.
	IMMED	The patch switches instantly when a BANK pedal or any of the number pedals is pressed.

Parameter	Value	Explanation
EXP PEDAL HOLD	OFF	The operational status of the EXP PEDAL's FUNC (p. 31) is not carried over when patches are switched.
	ON	If the EXP PEDAL's FUNC (p. 31) are the same between 2 patches, the operational status is carried over when patches are switched. For example, if EXP PEDAL FUNC is set to FOOT VOLUME in both patches, the one before and the one after the change, the volume corresponding to the position the pedal is in (angle) at the time of the patch change will be maintained after the patch change. On the other hand, if the patch being changed to is set to WAH, the volume will be in accordance with the value set within the patch, and you'll obtain a wah effect that is in accordance with a value that reflects the current position (angle) of the pedal.
KNOB LOCK	OFF, ON	Specifies whether knob operations will be disabled. If this is ON, knob operations will be disabled.
NUM PEDAL SW	OFF, TUNER, Ch. A/B, OD SOLO, A/B SOLO, A&B SOLO	Selects the function that will be recalled when you press the pedal of the same number as the currently selected patch.
BANK EXTENT MIN	P01–P50, U01–U50	Sets the lower limit for the banks.
BANK EXTENT MAX	P01–P50, U01–U50	Sets the upper limit for the banks.
PEDAL INDICAT	OFF, ON	If this is ON, all currently unlit pedal indicators will blink dimly.

KNOB SETTING

Here you can assign the desired parameters to knobs [1]–[8] in the Play Screen.

* The settings you make here are only for the knobs in the Play Screen.

Parameter	Value
KNOB 1	OFF, PATCH, COMP SUSTAIN, COMP ATTACK, COMP LEVEL, OD/DS DRIVE, OD/DS TONE, OD/DS E.LEV, OD/DS SOLO LV, PRE A TYPE, PRE A GAIN, PRE A LEVEL, PRE A BASS, PRE A MID, PRE A TREBLE, PRE A PRES, PRE A SOLO LV, PRE A MIC LEV, PRE B TYPE, PRE B GAIN, PRE B LEVEL, PRE B BASS, PRE B MID, PRE B TREBLE, PRE B PRES, PRE B SOLO LV, PRE B MIC LEV, EQ LO CUT, EQ LOW, EQ LO-MID, EQ HI-MID, EQ HIGH, EQ HI CUT, DELAY TIME, DELAY F.BACK, DELAY HI CUT, DELAY E.LEV, DELAY D1TIME, DELAY D1F.BK, DELAY D1HICUT, DELAY D1LEV, DELAY D2TIME, DELAY D2F.BK, DELAY D2HICUT, DELAY D2LEV, CHORUS RATE, CHORUS DEPTH, CHORUS PREDLY, CHORUS E.LEV, REVERB TIME, REVERB HI CUT, REVERB E.LEV, MASTER LOW, MASTER MID, MASTER HIGH, PATCH LEVEL, PEDAL WAH LEV, PEDAL PB LEV, DIV CH SELECT, SR SEND LEVEL, SR RTN LEVEL, NS1 THRESH, NS1 RELEASE, NS2 THRESH, NS2 RELEASE, GLOBAL EQ LOW, GLOBAL EQ MID, GLOBAL EQ HIGH

Display of parameters you can set with KNOB SETTING

The parameter names displayed in the Play screen are abbreviated. For details about the parameter names, refer to the chart shown below.

Value	Display	Value	Display
OFF	OFF	DELAY F.BACK	DlyFBK
PATCH	PATCH	DELAY HI CUT	DlyHC
COMP SUSTAIN	CmpSUS	DELAY E.LEV	DlyELV
COMP ATTACK	CmpATK	DELAY D1TIME	D1 TIM
COMP LEVEL	CmpLEV	DELAY D1F.BK	D1 FBK
OD/DS DRIVE	OD DRV	DELAY D1HICUT	D1 HC
OD/DS TONE	OD TNE	DELAY D1LEV	D1 LEV
OD/DS E.LEV	OD ELV	DELAY D2TIME	D2 TIM
OD/DS SOLO LV	OD SLV	DELAY D2F.BK	D2 FBK
PRE A TYPE	A:TYPE	DELAY D2HICUT	D2 HC
PRE A GAIN	A:GAIN	DELAY D2LEV	D2 LEV
PRE A LEVEL	A:LEV	CHORUS RATE	ChoRAT
PRE A BASS	A:BASS	CHORUS DEPTH	ChoDPT
PRE A MID	A:MID	CHORUS PREDLY	ChoDLY
PRE A TREBLE	A:TRB	CHORUS E.LEV	ChoLEV
PRE A PRES	A:PRES	REVERB TIME	RevTIM
PRE A SOLO LV	A:SLV	REVERB HI CUT	RevHC
PRE A MIC LEV	A:MLV	REVERB E.LEV	RevELV
PRE B TYPE	B:TYPE	MASTER LOW	MT LOW
PRE B GAIN	B:GAIN	MASTER MID	MT MID
PRE B LEVEL	B:LEV	MASTER HIGH	MT HI
PRE B BASS	B:BASS	PATCH LEVEL	PAT LV
PRE B MID	B:MID	PEDAL WAH LEV	WahLEV
PRE B TREBLE	B:TRB	PEDAL PB LEV	PB LEV
PRE B PRES	B:PRES	DIV CH SELECT	CH A/B
PRE B SOLO LV	B:SLV	SR SEND LEVEL	SR SND
PRE B MIC LEV	B:MLV	SR RTN LEVEL	SR RTN
EQ LO CUT	EQ LC	NS1 THRESH	NS1THR
EQ LOW	EQ LOW	NS1 RELEASE	NS1REL
EQ LO-MID	EQ LMD	NS2 THRESH	NS2THR
EQ HI-MID	EQ HMD	NS2 RELEASE	NS2REL
EQ HIGH	EQ HI	GLOBAL EQ LOW	GB LOW
EQ HI CUT	EQ HC	GLOBAL EQ MID	GB MID
DELAY TIME	DlyTIM	GLOBAL EQ HIGH	GB HI

SYSTEM

PREFERENCE

Here you can specify whether settings for the type of connected amp and preamp, control pedal, expression pedal, etc. will be independent for each patch, or whether the same settings will be shared by all patches.

Parameter	Value	Explanation
OUTPUT SELECT	PATCH, SYSTEM	If this is set to PATCH, different settings can be made independently for each patch. If this is set to SYSTEM, the same settings will be shared by all patches. * Here, even if a CTL/EXP pedal that has been set to SYSTEM is set to ASSIGN SOURCE (p. 32), that setting will be ignored. In the case of the ACCEL/CTL pedal, in addition to the above, settings for Manual mode (p. 37) will also be ignored.
PREAMP	PATCH, SYSTEM 1-3	
ACCEL/CTL	PATCH, SYSTEM	
EXP	PATCH, SYSTEM	
EXP SW	PATCH, SYSTEM	
SUB CTL 1	PATCH, SYSTEM	
SUB CTL 2	PATCH, SYSTEM	
SUB EXP	PATCH, SYSTEM	

LCD

Here you can adjust the brightness of the characters in the display.

Parameter	Value	Explanation
CONTRST LEFT	1-16	Higher values increase the brightness.
CONTRST RIGHT		

USB

Here you can make USB-related settings for when the GT-100 is connected to a computer via USB.

USB audio flow

USB IN-OUT MODE: NORMAL

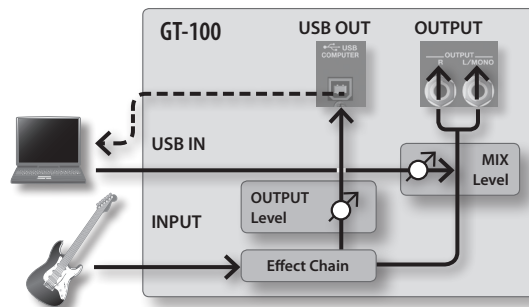

USB IN-OUT MODE: DRY OUT

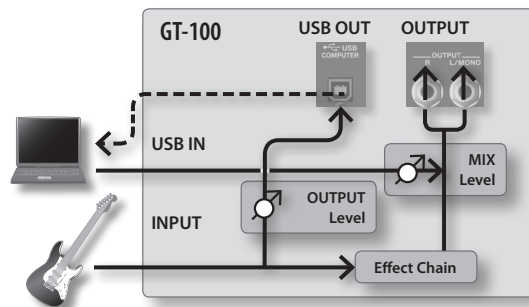

USB IN-OUT MODE: REAMP

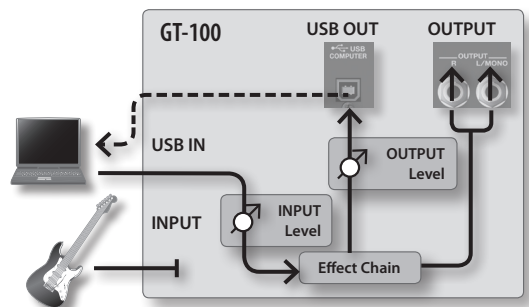

Parameter	Value	Explanation
USB IN-OUT MODE		Here you can specify the audio flow for USB input/output.
	NORMAL	The guitar input will be sent through the GT-100's effects and output to the computer. The input from the computer will be mixed with the GT-100's output, and then output.
	DRY OUT	The sound of the guitar processed by the effects will be monitored, while the guitar input will be output to the computer without passing through the GT-100's effects. The input from the computer will be mixed with the GT-100's output (effect-processed guitar sound) and then output.
	REAMP	The sound being input from the computer will pass through the GT-100's effects, and then be output from the GT-100's OUTPUT and USB OUT. With this setting, the guitar sound recorded on the computer can be played back through the GT-100's effects and output from the GT-100's guitar OUTPUT and USB OUT. * If REAMP is selected, the GT-100's INPUT cannot be used.

Parameter	Value	Explanation
MIX LEVEL		Adjusts the level of the audio input from the computer that will be mixed with the sound processed by the GT-100's effects when "USB IN-OUT MODE" is not set to "REAMP".
	0–200 %	Adjusts the level of the audio input from the computer that will be mixed with the sound processed by the GT-100's effects.
INPUT LEVEL		Adjusts the input level from the computer to the GT-100's effects when "USB IN-OUT MODE" is set to "REAMP".
	-20–+20 dB	Adjusts the input level from the computer to the GT-100's effects .
OUTPUT LEVEL		Adjusts the level of the output from the GT-100 to the computer.
	0–200%	Adjusts the level of the output to the computer.
DIR. MONITOR		Switches the output of the GT-100 sound to the OUTPUT and PHONES jacks. * This setting cannot be saved. It is set to ON when the power is turned on. * If you are using the special driver, you can control DIR. MONITOR On/Off from ASIO 2.0 - compatible application.
	OFF	Set this to Off if transmitting audio data internally through a computer (Thru). No sound is heard at this time unless the setting for the computer is Thru.
	ON	The GT-100 sound is output. Set this to ON when using the GT-100 as a standalone device, without connecting to a computer (only USB input sound will be output if this is set to Off).
DIR. MONITOR CMD		This setting determines whether or not the command (the Direct Monitor command) controlling the Direct Monitor setting is enabled.
	DISABLE	The Direct Monitor command is disabled, maintaining the Direct Monitor mode set by the GT-100.
	ENABLE	The Direct Monitor command is enabled, allowing the Direct Monitor mode to be switched from an external device.

MIDI SETTING

Here you can make settings for using the GT-100 connected with an external MIDI device or with a second GT-100 unit.

Parameter	Value	Explanation
RX CHANNEL		This sets the MIDI channel used for receiving MIDI messages.
	Ch. 1– Ch. 16	Specifies the receive channel.
OMNI MODE		This makes the settings for the channels used for MIDI information.
	OFF	Information is received on the channel specified by the RX CHANNEL setting.
	ON	Messages are received on all channels, regardless of the MIDI channel settings.
TX CHANNEL		This sets the MIDI channel used for transmitting MIDI messages.
	Ch. 1– Ch. 16.	Specifies the transmit channel.
	RX	Transmits on the same channel as the RX CHANNEL.
DEVICE ID		This sets the MIDI Device ID used for transmitting and receiving Exclusive messages.
	1–32	Sets the MIDI Device ID.

Parameter	Value	Explanation
SYNC CLOCK		This setting determines the basis used for synchronizing the timing for effect modulation rates and other time-based parameters. * When you have an external MIDI device connected, the MASTER BPM is then synchronized to the external MIDI device's tempo, thus disabling the MASTER BPM setting. To enable setting of the MASTER BPM, set to "INTERNAL." * When synchronizing performances to the MIDI Clock signal from an external MIDI device, timing problems in the performance may occur due to errors in the MIDI Clock.
	AUTO	Operations are synchronized to the MIDI Clock received via MIDI. However, operations are automatically synchronized to the GT-100's internal Clock if the GT-100 is unable to receive the external Clock.
	INTERNAL	Operations are synchronized to the GT-100's internal Clock.
MIDI IN SELECT		This selects whether MIDI messages will be received from the MIDI IN connector or from the USB port.
	USB (AUTO)	MIDI messages will be received via the USB port. * If the USB port is not connected to a computer, MIDI messages will be received from the MIDI IN connector.
	MIDI	MIDI messages will be received from the MIDI IN connector.
PC OUT		This setting determines whether or not Program Change messages are output when patches are switched on the GT-100. * On the GT-100, Bank Select messages are output simultaneously with Program Change messages.
	OFF	Program Change messages are not output, even when patches are switched.
	ON	Program Change messages are simultaneously output when patches are switched.
MAP SELECT		This setting determines whether patches are switched according to the Program Change Map settings, or to the default settings.
	FIX	This deactivates the Program Change Map. Switches to the patches according to the default settings.
	PROG	This activates the Program Change Map. Switches to the patches according to the Program Change Map.
PH.LOOP OUT		This sets the controller number when [PHRASE LOOP] pedal switch operation data is output as Control Change messages.
	OFF	Control Change messages are not output.
	CC#1–CC#31, CC#64–CC#95	This sets the controller number when [PHRASE LOOP] pedal operation data is output as Control Change messages.
ACC/CTL OUT		This sets the controller number when [ACCEL/CTL] pedal switch operation data is output as Control Change messages.
	OFF	Control Change messages are not output.
	CC#1–CC#31, CC#64–CC#95	This sets the controller number when [ACCEL/CTL] pedal operation data is output as Control Change messages.
EXP OUT		This sets the controller number when [EXP] pedal operation data is output as Control Change messages.
	OFF	Control Change messages are not output.
	CC#1–CC#31, CC#64–CC#95	This sets the controller number when [EXP] pedal operation data is output as Control Change messages.
EXP SW OUT		This sets the controller number when EXP PEDAL SW operation data is output as Control Change messages.
	OFF	Control Change messages are not output.
	CC#1–CC#31, CC#64–CC#95	This sets the controller number when EXP PEDAL SW operation data is output as Control Change messages.

SYSTEM

Parameter	Value	Explanation
SUB CTL 1 OUT		This sets the controller number when operation data from the footswitch connected to the SUB CTL 1, 2/SUB EXP jack is output as Control Change messages.
	OFF	Control Change messages are not output.
	CC#1–CC#31, CC#64–CC#95	This sets the controller number when SUB CTL 1 pedal operation data is output as Control Change messages.
SUB CTL 2 OUT		This sets the controller number when operation data from the footswitch connected to the SUB CTL 1, 2/SUB EXP jack is output as Control Change messages.
	OFF	Control Change messages are not output.
	CC#1–CC#31, CC#64–CC#95	This sets the controller number when SUB CTL 2 pedal operation data is output as Control Change messages.
SUB EXP OUT		This sets the controller number when operation data from the expression pedal connected to the SUB CTL 1, 2/SUB EXP jack is output as Control Change messages.
	OFF	Control Change messages are not output.
	CC#1–CC#31, CC#64–CC#95	This sets the controller number when external SUB EXP Pedal operation data is output as Control Change messages.

MIDI PROGRAM MAP BANK 0–3

When switching patches using Program Change messages transmitted by an external MIDI device, you can freely set the correspondence between Program Change messages received by the GT-100 and the patches to be switched to in the “Program Change Map.”

Parameter	Value	Explanation
PC#1–PC#128	U01-1–U50-4, P01-1–P50-4	This sets the patch number (P01-1 through U50-4) for the corresponding Program Change number.

MIDI BULK DUMP

You can use Exclusive messages to provide another GT-100 with identical settings, and save effect settings on a MIDI sequencer or other device.

Parameter	Value	Explanation
FROM	SYSTEM	System parameter settings
	QUICK	Settings for User Quick Setting
	U01-1–U50-4	Settings for Patch Number U01-1 through U50-4
	TEMP	Settings for the patch that is currently selected
TO	SYSTEM	System parameter settings
	QUICK	Settings for User Quick Setting
	U01-1–U50-4	Settings for Patch Number U01-1 through U50-4
	TEMP	Settings for the patch that is currently selected

PEDAL CALIBRATION

You can readjust the [EXP] pedal so that it will operate optimally.

Parameter	Value	Explanation
THRESHOLD	1–16	Adjusts the sensitivity at which the EXP PEDAL SW will respond.

AUTO OFF

The GT-100 can turn off its power automatically. The power will turn off automatically when 10 hours have passed since you last played or operated the unit. The display will show a message approximately 15 minutes before the power turns off.

With the factory settings, this function is turned “ON” (power-off in 10 hours). If you want to have the power remain on all the time, turn it “OFF.”

* When the power is turned off, any settings you were editing will be lost. You must save settings that you want to keep.

Parameter	Value	Explanation
AUTO OFF	OFF	The power will not turn off automatically.
	ON	The power will automatically turn off when 10 hours have passed since you last played or operated the GT-100.

FACTORY RESET

Initializes the GT-100 to its factory-set condition. Refer to “Restoring the Factory Settings.”

Parameter	Value	Explanation
FROM	SYSTEM	System parameter settings
	QUICK	Settings for User Quick Setting
	U01-1–U50-4	Settings for Patch Number U01-1 through U50-4
TO	SYSTEM	System parameter settings
	QUICK	Settings for User Quick Setting
	U01-1–U50-4	Settings for Patch Number U01-1 through U50-4

ACCEL/CTL, EXP SW, SUB CTL 1, SUB CTL 2

Here's how to assign the parameters that will be controlled by the ACCEL/CTL, EXP SW, SUB CTL 1 and SUB CTL 2 pedals.

Parameter	Value	Explanation
	OFF	No assignment.
	ACCEL	Switches the ACCEL effect on and off.
	PLOOP ON/OFF	Switches the PHRASE LOOP on and off.
	PLOOP REC/PLY	Records/plays back the phrase.
	PLOOP STP/PLY	Stops/plays back the phrase.
	PLOOP CLEAR	Clears the phrase
	DIV CH SELECT	Switches between Preamp channel A and B.
	OD/DS SOLO	Switches the OD/DS SOLO on and off.
	A/B SOLO	Switches the Preamp SOLO on and off.
	A&B SOLO	Switches the preamp SOLO, for both channel A and B, on and off. If one of the two channels is off, both will be turned on.
	COMP	Switches the COMP on and off.
	OD/DS	Switches the OD/DS on and off.
	PREAMP	Switches the PREAMP/SPEAKER on and off.
	EQ	Switches the EQ on and off.
	FX1	Switches the FX1 on and off.
	FX2	Switches the FX2 on and off.
	DELAY	Switches the DELAY on and off.
	CHORUS	Switches the CHORUS on and off.
	REVERB	Switches the REVERB on and off.
	PEDAL FX	Switches the Pedal FX on and off.
	SEND/RETURN	Switches the SEND/RETURN on and off.
	AMP CTL	Switches the Amp Control on and off.
FUNC	TUNER	Switches the TUNER/BYPASS on and off.
	MANUAL MODE	Switches the MANUAL MODE on and off.
	BPM TAP *1	Used for tap input of the MASTER BPM.
	DELAY TAP *1	Used for tap input of the delay time.
	MIDI START	Controls the Start/Stop of external MIDI devices (such as sequencers).
	MMC PLAY	Controls the Play/Stop of external MIDI devices (such as hard disk recorders).
	LEVEL +10 *1	Increases the patch volume level by 10 units.
	LEVEL +20 *1	Increases the patch volume level by 20 units.
	LEVEL -10 *1	Decreases the patch volume level by 10 units.
	LEVEL -20 *1	Decreases the patch volume level by 20 units.
	NUMBER INC *1	Switches to the next higher patch number in the same bank as the currently selected patch.
	NUMBER DEC *1	Switches to the next lower patch number in the same bank as the currently selected patch.
	BANK INC *1	Switches to the next higher bank number.
	BANK DEC *1	Switches to the next lower bank number.
	LED ON/OFF	Lights/extinguishes the pedal's LED indicator. * This is shown only when ACCEL/CTL pedal is selected. * This is shown only if PERFORMANCE (p. 28) is set to PATCH.

*1 The function will activate as soon as you press the pedal, regardless of whether the SOURCE MODE parameter is MOMENT or TOGGLE.

Parameter	Value	Explanation
MIN	OFF, ON (or STOP, START)	This sets the value for times when the switch is Off.
MAX	OFF, ON (or STOP, START)	This sets the value for times when the switch is On.
SOURCE MODE		This sets the behavior of the value each time the switch is operation.
	MOMENT	The normal state is Off (minimum value), with the switch On (maximum value) only while the footswitch is depressed.
	TOGGLE	The setting is toggled On (maximum value) or Off (minimum value) with each press of the footswitch.

EXP, SUB EXP

Here's how to assign the parameters that will be controlled by the GT-100's [EXP] pedal, and by an expression pedal (such as the separately available EV-5) connected to the SUB CTL 1, 2/SUB EXP jack.

Parameter	Value	Explanation
FUNC	OFF	No assignment.
	FOOT VOLUME	Foot volume will be assigned.
	PEDAL BEND	Pedal bend will be assigned.
	WAH	Wah will be assigned.
	PB/FV	Pedal bend and foot volume will be assigned.
	WAH/FV	Wah and foot volume will be assigned.
	PATCH LEVEL	Patch level will be assigned. * This is shown only if PERFORMANCE (p. 28) is set to SYSTEM.
PATCH LEVEL MIN	0-200	Specifies the minimum value. * This is shown only if FUNC is set to PATCH LEVEL.
PATCH LEVEL MAX	0-200	Specifies the maximum value. * This is shown only if FUNC is set to Patch Level.

* Only FOOT VOLUME can be assigned to SUB EXP (external expression pedal). If you want to assign a function other than FOOT VOLUME, use Assign.







ASSIGN COMMON

Parameter	Value	Explanation
INPUT SENS	0-100	This adjusts the input sensitivity when INPUT LEVEL is selected for SOURCE.

ASSIGN 1-8

* If you want to light the ACCEL/CTL pedal's LED indicator while the ASSIGN 1-8 function is assigned to the ACCEL/CTL pedal, set the ACCEL/CTL pedal FUNC (p. 31) to "LED ON/OFF."

Parameter	Value	Explanation
OFF/ON	OFF, ON	Turns the ASSIGN 1-8 on/off.
SOURCE	EXP PEDAL	Assigns the GT-100's [EXP] pedal.
	EXP PDL SW	Assigns the EXP pedal switch.
	PLOOP PEDAL	Assigns the GT-100's [PHRASE LOOP] pedal.
	ACC/CTL PDL	Assigns the [ACCEL/CTL] pedal.
	SUB EXP PDL	Assigns the external expression pedal (such as the separately available EV-5) connected to the SUB CTL 1, 2/SUB EXP jack.
	SUB CTL1 PDL	Assigns the external footswitch (FS-5U, FS-6; available separately) connected to the SUB CTL 1, 2/SUB EXP jack.
	SUB CTL2 PDL	Assigns the external foot switch (FS-5U, FS-6; available separately) connected to the SUB CTL 1, 2/SUB EXP jack.
	INT PEDAL	Refer to "Virtual expression pedal system (Internal Pedal / Wave Pedal)" (p. 35)
	WAVE PEDAL	Refer to "Virtual expression pedal system (Internal Pedal / Wave Pedal)" (p. 35)
	INPUT LEVEL	The assigned target parameter will change according to the input level.
SOURCE MODE	CC#1-#31	Control Change messages from an external MIDI device.
	CC#64-#95	Control Change messages from an external MIDI device.
	MOMENT	The normal state is Off (minimum value), with the switch On (maximum value) only while the footswitch is depressed.
	TOGGLE	The setting is toggled On (maximum value) or Off (minimum value) with each press of the footswitch.
TARGET CATEGORY	This selects the parameter to be changed. Refer to TARGET list	
TARGET		
TARGET MIN	This sets the minimum value for the range in which the parameter can change. The value differs depending on the parameter assigned for TARGET parameter.	
TARGET MAX	This sets the maximum value for the range in which the parameter can change. The value differs depending on the parameter assigned for TARGET parameter.	
ACT RANGE LO	0-126	You can set the controllable range for target parameters within the source's operational range. Target parameters are controlled within the range set with ACT RANGE LO and ACT RANGE HI. You should normally set ACT RANGE LO to 0 and ACT RANGE HI to 127.
ACT RANGE HI	1-127	
WAVE RATE *1	0-100, BPM 	This determines the time spend for one cycle of the assumed EXP Pedal.
	When set to BPM, the value of each parameter will be set according to the value of the "MASTER BPM" specified for each patch. This makes it easier to achieve effect sound settings that match the tempo of the song. * If, due to the tempo, the time is longer than the range of allowable settings, it is then synchronized to a period either 1/2 or 1/4 of that time.	

Parameter	Value	Explanation
WAVEFORM *1	SAW	
	TRI	
	SINE	
INT PDL TRIGGER *2	PATCH CHANGE	This is activated when a patch is selected.
	EXP PDL-LO	This is activated when the GT-100's [EXP] pedal is set to the minimum position.
	EXP PDL-MID	This is activated when the GT-100's [EXP] pedal is moved through the middle position.
	EXP PDL-HI	This is activated when the GT-100's [EXP] pedal is set to the maximum position.
	EXP PDL SW	This is activated when the EXP pedal switch is operated.
	PLOOP PEDAL	This is activated when the [PHRASE LOOP] pedal is operated.
	ACC/CTL PDL	This is activated when the [ACCEL/CTL] Pedal is operated.
	SUB EXP PDL	This is activated when an external expression pedal connected to the SUB CTL 1, 2/SUB EXP jack is operated.
	SUB CTL1 PDL	This is activated when an external footswitch connected to the SUB CTL 1, 2/SUB EXP jack is operated.
	SUB CTL2 PDL	This is activated when an external footswitch connected to the SUB CTL 1, 2/SUB EXP jack is operated.
INT PDL TIME *2	CC#1-#31	This is activated when a control change is received.
	CC#64-#95	This is activated when a control change is received.
INT PDL CURVE *2	0-100	This specifies the time over which the internal pedal will move from the toe-raised position to the toe-down position.
	LINEAR	
	SLOW RISE	
	FAST RISE	

*1 The WAVE RATE and WAVEFORM parameters are enabled when the Source parameter is set to WAVE PEDAL.

*2 The INT PDL TRIGGER, INT PDL TIME, and INT PDL CURVE parameters are enabled when the SOURCE parameter is set to INT PEDAL.

TARGET list

CATEGORY	TARGET	CATEGORY	TARGET	CATEGORY	TARGET	CATEGORY	TARGET		
COMP	ON/OFF	EQ	ON/OFF	FX1/FX2 GEQ	31 Hz	FX1/FX2 OCTAVE	RANGE		
	TYPE		LOW CUT		62Hz		OCTAVE LEVEL		
	SUSTAIN		LOW GAIN		125 Hz		DIRECT MIX		
	ATTACK		LOW-MID FREQ		250 Hz		VOICE		
	TONE		LOW-MID Q		500 Hz		PS1 MODE		
	LEVEL		LOW-MID GAIN		1 kHz		PS1 PITCH		
OD/DS	ON/OFF		HI-MID FREQ		2 kHz	FX1/FX2 P.SHIFT	4 kHz	PS1 FINE	
	TYPE		HI-MID Q		8 kHz		PS1 PRE DLY		
	DRIVE		HI-MID GAIN		16 kHz		PS1 LEVEL		
	BOTTOM		HIGH GAIN		LEVEL		PS2 MODE		
	TONE		HIGH CUT		LOW CUT		PS2 PITCH		
	SOLO SW		ON/OFF		LOW GAIN		PS2 FINE		
	SOLO LEVEL	TYPE	LOW-MID FREQ	PS2 PRE DLY					
	EFFECT LEVEL	MODE	LOW-MID Q	PS2 LEVEL					
	DIRECT MIX	POLARITY	LOW-MID GAIN	PS1 F.BACK					
	CUSTOM TYPE	SENS	HI-MID FREQ	DIRECT MIX					
	CUSTOM BOTTOM	FREQ	HI-MID Q	FX1/FX2 HARM	VOICE				
	CUSTOM TOP	PEAK	HI-MID GAIN		HR1 HARMONY				
	CUSTOM LOW	EFFECT LEVEL	HIGH CUT		HR1 PRE DLY				
	CUSTOM HIGH	DIRECT MIX	HIGH GAIN		HR1 LEVEL				
CUSTOM CHAR	MODE	LEVEL	HR2 HARMONY						
PREAMP	ON/OFF	FX1/FX2 A.WAH	FREQ		FX1/FX2 ToneMOD	TYPE	FX1/FX2 S.HOLD	HOLD	
	TYPE		PEAK			RESO		RISE TIME	
	GAIN		RATE			LOW		EFFECT LEVEL	
	T-COMP		DEPTH			HIGH		FX1/FX2 AC.PRO	TYPE
	BASS		EFFECT LEVEL			LEVEL			BASS
	MIDDLE		DIRECT MIX			TYPE			MIDDLE
	TREBLE		TYPE			LOW			MIDDLE FREQ
	PRES		PDL POS			HIGH			TREBLE
	LEVEL		PEDAL MIN			BODY			PRES
	BRIGHT		PEDAL MAX	LEVEL		LEVEL			
	GAIN SW		EFFECT LEVEL	SENS		FX1/FX2 PHASER			TYPE
	SOLO SW		DIRECT MIX	RISE TIME					RATE
	SOLO LEVEL	TYPE	LEVEL	DEPTH					
	SP TYPE	FX1/FX2 SUB WAH	SUSTAIN	MANUAL					
	MIC TYPE		ATTACK	RESO					
	MIC DIST		TONE	EFFECT LEVEL					
	MIC POS		LEVEL	DIRECT MIX					
	MIC LEVEL		TYPE	WAVE					
DIRECT MIX	ATTACK		CUTOFF						
CUSTOM TYPE	THRESH		RESO						
CUSTOM BOTTOM	RATIO		FILTER SENS						
CUSTOM EDGE	RELEASE		FILTER DECAY						
CUSTOM LOW	LEVEL		FILTER DEPTH						
CUSTOM HIGH	TYPE		SYNTH LEVEL						
CUSTOM CHAR	DRIVE		DIRECT MIX						
SPCSTM SIZE	BOTTOM	TONE	FX1/FX2 FLANGER	RATE					
SPCSTM COLOR L	TONE	SOLO SW		DEPTH					
SPCSTM COLOR H	SOLO SW	SOLO LEVEL		MANUAL					
SPCSTM SP NUM	SOLO LEVEL	EFFECT LEVEL		RESO					
SPCSTM CABINET	EFFECT LEVEL	DIRECT MIX		SEPARATION					
PREAMP A/B	DIRECT MIX	FX1/FX2 LIMITER		THRESH	FX1/FX2 DEFRET	WAVE	FX1/FX2 TREMOLO	LOW CUT	
	CUSTOM TYPE			RATIO		RESO		EFFECT LEVEL	
	CUSTOM BOTTOM			RELEASE		BUZZ		DIRECT MIX	
	CUSTOM EDGE			LEVEL		EFFECT LEVEL		WAVE SHAPE	
	CUSTOM LOW			TYPE		DEPTH		RATE	
	CUSTOM HIGH			DRIVE		RESO		DEPTH	
	CUSTOM CHAR			BOTTOM		BUZZ		LEVEL	
	SPCSTM SIZE		TONE	EFFECT LEVEL		FX1/FX2 SitarSIM		WAVE SHAPE	
	SPCSTM COLOR L		SOLO SW	DIRECT MIX				RATE	
	SPCSTM COLOR H		SOLO LEVEL	TONE				DEPTH	
	SPCSTM SP NUM		EFFECT LEVEL	SENS				RESO	
	SPCSTM CABINET		DIRECT MIX	DEPTH				BUZZ	
		EFFECT LEVEL	EFFECT LEVEL						

CATEGORY	TARGET	CATEGORY	TARGET	CATEGORY	TARGET	CATEGORY	TARGET		
FX1/FX2 ROTARY	SPEED SELECT	DELAY	ON/OFF	DIVIDER	MODE	MASTER	PATCH LEVEL		
	RATE SLOW		TYPE		CHANNEL SELECT		MASTER LOW		
	RATE FAST		DELAY TIME		ChA DYNAMIC		MASTER MID F		
	RISE TIME		F.BACK		ChA DYN SENS		MASTER MID Q		
	FALL TIME		HIGH CUT		ChA FILTER		MASTER MID G		
	DEPTH		EFFECT LEVEL		ChA CUTOFF		MASTER HIGH		
	LEVEL		DIRECT MIX		ChB DYNAMIC		BPM/ KEY	MASTER BPM	
	PAN TAP TIME	ChB DYN SENS	MASTER KEY						
FX1/FX2 UNIV	RATE	DELAY D1	TIME	MIXER	MODE	TUNER	TUNER SW		
	DEPTH		F.BACK		ChA/B BALANCE		MANUAL	MANUAL MODE SW	
	LEVEL		HIGH CUT		SPREAD			PHRASE LOOP	ON/OFF
FX1/FX2 PAN	TYPE	DELAY D2	LEVEL	SEND/ RETURN	ON/OFF	TAP			BPM TAP
	WAVE SHAPE		TIME		MODE		DELAY TAP		
	RATE		F.BACK		SEND LEVEL		MIDI	START/ STOP	
	DEPTH		HIGH CUT		RETURN LEVEL			MMC PLY /STOP	
	POS		LEVEL		AMP CTL			AMP CTL SW	
LEVEL	MOD. RATE	NS1	ON/OFF	NS2	ON/OFF	PATCH	LEVEL +10		
FX1/FX2 SLICER	RATE		MOD. DEPTH		THRESH		THRESH	LEVEL +20	
	TRIGGER SENS		ON/OFF		RELEASE		RELEASE	LEVEL -10	
	EFFECT LEVEL		MODE		DETECT		DETECT	LEVEL -20	
	DIRECT MIX		RATE		ACCEL		ON/OFF	NUMBER INC	
FX1/FX2 VIBRATO	RATE	DEPTH	THRESH	RELEASE			NUMBER DEC		
	DEPTH	PRE DELAY	DETECT	DETECT	BANK INC				
	TRIGGER	LOW CUT	ACCEL S-BEND	ON/OFF	BANK DEC				
	RISE TIME	HIGH CUT		THRESH	ON/OFF				
	LEVEL	EFFECT LEVEL	RELEASE	RELEASE					
			DETECT	DETECT					
FX1/FX2 RINGMOD	MODE	REVERB	ON/OFF	ACCEL LASER	ON/OFF	ACCEL RING	FREQ		
	FREQ		TYPE		PITCH		RISE TIME		
	EFFECT LEVEL		REVERB TIME		RISE TIME		FALL TIME		
	DIRECT MIX		PRE DELAY		DEPTH		FALL TIME		
FX1/FX2 HUMAN	MODE		LOW CUT	MANUAL	ACCEL TWIST		LEVEL	ACCEL WARP	LEVEL
	VOWEL 1		HIGH CUT	LEVEL			RISE TIME		
	VOWEL 2		DENSITY	LEVEL			FALL TIME		
	SENS		EFFECT LEVEL	MANUAL			RISE TIME		
	RATE		DIRECT MIX	LEVEL			FALL TIME		
	DEPTH		SPRING SENS	LEVEL			RISE TIME		
			LEVEL	FALL TIME					
FX1/FX2 2x2CHO	MODE	PEDAL FX	ON/OFF	ACCEL RING	FREQ	ACCEL TWIST	LEVEL		
	XOVER FREQ		PITCH		RISE TIME		FALL TIME		
	LOW RATE		PDL POS		FALL TIME		RISE TIME		
	LOW DEPTH		EFFECT LEVEL		RING LEVEL		FALL TIME		
	LOW PRE DLY	DIRECT MIX	PEDAL P.B.	MANUAL	ACCEL TWIST	LEVEL	ACCEL WARP	LEVEL	
	LOW LEVEL	TYPE		LEVEL		RISE TIME			
	HIGH RATE	PDL POS		RISE TIME		FALL TIME			
	HIGH DEPTH	PEDAL MIN		FALL TIME		RISE TIME			
HIGH PRE DLY	PEDAL MAX	PEDAL WAH	EFFECT LEVEL	ACCEL WARP	LEVEL	ACCEL WARP	LEVEL		
HIGH LEVEL	EFFECT LEVEL		RISE TIME		FALL TIME				
TYPE	DIRECT MIX		DIRECT MIX		RISE TIME				
DELAY TIME	LEVEL		LEVEL		FALL TIME				
FX1/FX2 SUB DLY	F.BACK	FOOT VOLUME	VOLUME CURVE	ACCEL F.BACK	MODE	ACCEL F.BACK	MODE		
	HIGH CUT		VOLUME MIN		DEPTH		DEPTH		
	EFFECT LEVEL		VOLUME MAX		RISE TIME		RISE TIME		
	DIRECT MIX		LEVEL		OCTAVE R.TIME		OCTAVE R.TIME		
	TAP TIME				FB LEVEL		FB LEVEL		
					OCTAVE FB LEV		OCTAVE FB LEV		

Virtual expression pedal system (Internal Pedal / Wave Pedal)

By assigning a desired parameter to the virtual expression pedal, you can produce an effect as though you were operating a physical expression pedal to change the volume or tone quality in real time.

The virtual expression pedal system provides the following two types of functions, and you can use the SOURCE setting for ASSIGN 1–8 to choose the desired type.

* If you want to use the internal pedal or wave pedal, set the ASSIGN parameter SOURCE MODE to "MOMENT"

Internal pedal

If SOURCE is set to "INT PEDAL," the virtual expression pedal will begin operating when started by the specified trigger (INT PDL TRIGGER), modifying the parameter specified by TARGET.

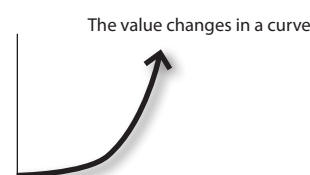

Wave pedal

If SOURCE is set to "WAVE PEDAL," the virtual expression pedal will cyclically modify the parameter specified by TARGET in a fixed wave form.

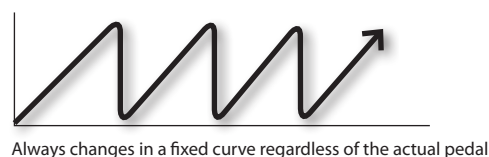

Input Level

Input level

The parameter set as the target changes in response to the input level.

MEMO

If you want to adjust the input sensitivity, set the INPUT SENS.

About the Range of a Target's Change

The value of the parameter selected as the target changes within the range defined by "Min" and "Max," as set on the GT-100.

When using an external footswitch, or other controller that acts as an on/off switch, "Min" is selected with Off (CLOSED), and "Max" is selected with On (OPEN).

When using an external expression pedal or other controller that generates a consecutive change in the value, the value of the setting changes accordingly, within the range set by the minimum and maximum values. Also, when the target is of an on/off type, the median value of the received data is used as the dividing line in determining whether to switch it on or off.

When using the footswitch:

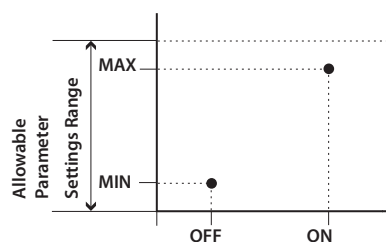

When using the expression pedal:

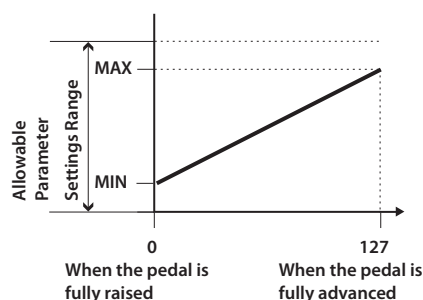

When controlling the On/Off target with the expression pedal:

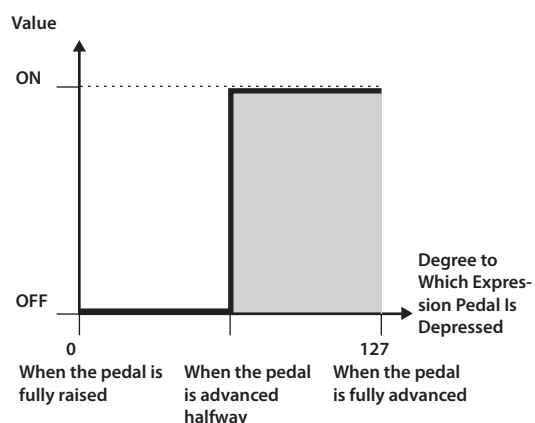

*The range that can be selected changes according to the target setting.

*When the "minimum" is set to a higher value than the "maximum," the change in the parameter is reversed.

*"The values of settings can change if the target is changed after the "minimum" and "maximum" settings have been made. If you've changed the target, be sure to recheck the "minimum" and "maximum" settings.

About the Range of a Controller's Change

This sets the operational range within which the value of the setting changes when an expression pedal or other controller that changes the value consecutively is used as the source. If the controller is moved outside the operational range, the value does not change, it stops at "minimum" or "maximum."

(Example) With ACT RANGE LO: 40, ACT RANGE HI: 80

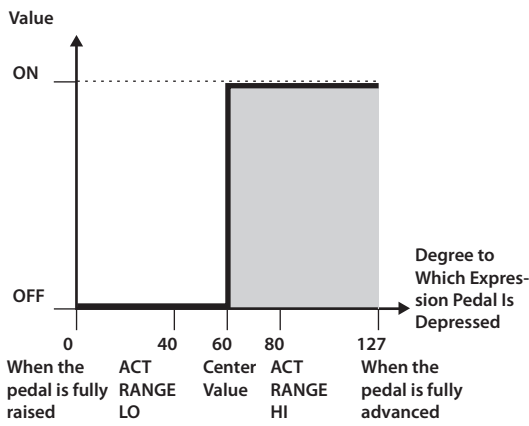
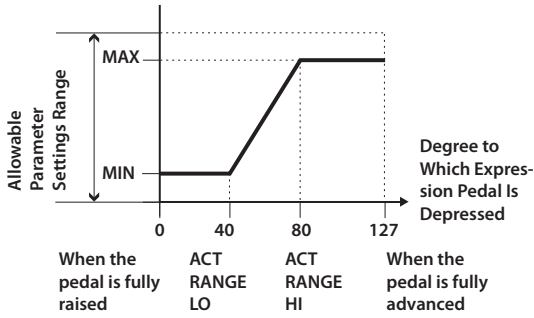

*When using a footswitch or other on/off switching controller as the source, leave these at "ACT RANGE LO: 0" and "ACT RANGE HI: 127." With certain settings, the value may not change.

Other Settings

TUNER METRONOME MODE

Editing procedure

1. Simultaneously press pedals [1] and [2].

The tuner function and the metronome function will turn on.



2. Use knobs [1], [4]–[8] to specify the settings.
3. Simultaneously press pedals [1] and [2] to return to the Play screen.
You can also return to the Play screen by pressing the [EXIT] button.

TUNER

Here you can make settings for the TUNER mode.

Parameter	Value	Explanation
PITCH	435 Hz–445 Hz	Specifies the reference pitch.
OUTPUT	MUTE	Sound will not be output while tuning.
	BYPASS	While tuning, the sound of the guitar being input to the GT-100 will be output without change. All effects will be off.
	THRU	Allows you to tune while hearing the current effect sound.

METRONOME

Here you can make settings for the METRONOME mode.

Parameter	Value	Explanation
TEMPO	40–250	Specifies the tempo of the metronome.
BEAT	1/1–8/1, 1/2–8/2, 1/4–8/4, 1/8–8/8	Selects the time signature.
ON/OFF	OFF, ON	Turns the metronome on/off.
LEVEL	0–100	Adjusts the volume of the metronome.

MANUAL MODE

Editing procedure

1. Simultaneously press pedals [BANK DOWN] and [BANK UP].

The MANUAL mode will turn on.



2. Use knobs [1]–[8] to specify the settings.
3. Simultaneously press pedals [BANK DOWN] and [BANK UP] to return to the Play screen.

Here you can make settings for the MANUAL mode.

Parameter	Value	Explanation
BANK DOWN	OFF, ACCEL, PL (PHRASE LOOP), PL R/P, PL S/P, PL CLR, CH A/B, OD SOLO, A/B SOLO, A&B SOLO, CMP, OD, PREAMP, EQ, FX1, FX2, DLY, CHO, REV, PDL FX, S/R, AMP CTL, TUNER, MANUAL, BPM TAP, DLY TAP, MIDI (MIDI START), MMC PLAY, LEV +10, LEV +20, LEV -10, LEV -20, NUM INC, NUM DEC, BANK INC, BANK DEC	You can assign the desired effects unit to each pedal.
BANK UP		
NUMBER PEDAL 1		
NUMBER PEDAL 2		
NUMBER PEDAL 3		
NUMBER PEDAL 4		
PHRASE LOOP		
ACCEL/CTL		

BOSS